



## **Background**

At the March 2005 meeting of the Southern Territory's Disaster Committee, a sub-committee on standards for canteens presented an initial report on its findings regarding the standardization of canteen design. Included in this presentation was information regarding standards for lettering, logos and decals.

The sub-committee's mission was to facilitate consistency in lettering and decaling (text, placement, size and font) of The Southern Territory's deployable, mobile vehicles used primarily for disaster use.

As an outcome, the following standards for lettering, logos and decals on disaster vehicles was created and approved by The Salvation Army Southern Territory.

## **Observations and Findings:**

- The standards reflected in this document should be applied to new, re-modeled, renovated and/or re-painted units within 5 years of the standard's original approval date.
- In accordance with the recommendations in this standard, and with existing Territorial Minutes and policies governing the purchase of disaster equipment (PL035) and restrictions on color (013D), any division that does not adhere to this standard will forfeit their 40% territorial match funding for vehicle purchase and reimbursement for lettering.
- Expenses incurred by a division to comply with the lettering, signage and logos explained herein should be considered disaster expenditures and as such be 100% funded from territorial disaster funds.
- Any additional marking other than the lettering and logos recommended in this territorial standard are considered unauthorized and must be approved by territorial headquarters prior to use.
- All mobile equipment will have a divisional/unit designation as outlined herein.
- The size of logos/lettering in the following standard and photos is in inches and suggested. Every effort should be made by a division to maximize the use of the available "white space" on the units while using prudent good judgment in applying the recommended standards.



## TABLE OF CONTENTS

---

### Unit I.D. Numbering System

- Territorial Identification *page 5*

### Divisional Identification

- Unit Designator *page 5*
- Donor Recognition *page 5*

### Graphics and Lettering

- Colors *page 7*
- Vinyl *page 7*
- Fonts *page 7*
- White Space *page 7*
- Proportion *page 7*

### Specific Recommendations

- Custom Mobile Food Equipment 15' Canteen *page 9-12*
- Custom Mobile Food Equipment 18' Canteen *page 13-16*
- Keystone Coachworks 12' DRU *page 17-20*
- Keystone Coachworks 16' DRU *page 21-24*
- Catering Truck *page 25-30*
- Utility/Cargo Trailer *page 31-34*
- Trailer Canteen *page 35-38*
- Box Truck *page 39-42*
- Tractor Trailer *page 43-46*
- Command Vehicles, Support Vehicles *page 47-50*
- Donor Recognition placement *page 51-52*



## **UNIT I.D. NUMBERING SYSTEM**

---

### **Numbering, Location & Detail:**

All units shall have alphanumeric identification with a height of no less than 2 and no more than 5 inches depending on the size and type of the unit, state law or other mitigating factors. Unit identifications are to be applied on both the front and rear of the vehicle. Numbers on the roof of the vehicle is optional. All fonts shall be done in Arial Bold.

### **Territorial Identification:**

The first character indicates the territory as follows:

- C Central Territory
- E Eastern Territory
- N National Headquarters
- S Southern Territory
- W Western Territory

### **Divisional Identification:**

The next three characters are the Divisional designator, per Lotus Notes (with some divisions having only two characters) i.e.

- EMI Eastern Michigan Division / Central Territory
- EMP Empire State Division / Eastern Territory
- TX Texas Division / Southern Territory
- SDM Sierra Del Mar Division / Western Territory

### **Unit Designator:**

At the discretion of each territory, the 5<sup>th</sup>, 6<sup>th</sup>, and 7<sup>th</sup> characters must be used to denote a vehicle inventory number, vehicle type, zone number, or other information important to that Territory or Division within that Territory. The 5<sup>th</sup>, 6<sup>th</sup>, and 7<sup>th</sup> characters are optional and more characters may be used in addition those if desired by the division.

- These three characters must be numeric.
- No division can have two vehicles with the same unit number.
- Local, professional vendors will ensure the application of these standards to the vehicles.

### **Donor Recognition:**

- An area of a disaster vehicle no larger than 28" x 9" may be allocated for the donor's logo/lettering.
- Recognition of local and divisional donors must be approved in advance by territorial headquarters.
- While the size of the gift should be taken into account, appropriate application of donor logo/lettering will inform the application of this standard.
- The space allocated for any one donor is to include appropriate use of available white space.
- Placement must be on either side of the canteen at or below the level of the serving window.
- Placement may not be on the front, back or roof.
- For Canteen Trailers, the area can be the rear door instead of the sides.
- See page 51 for example.



## GRAPHICS & LETTERING

---

### Colors:

- Where graphics/lettering/logos are noted in **red**, use PMS 185 Red
- All letters and numbers shall be **red**, with the exception of:
- “Doing the Most Good” shall be **black** or as otherwise indicated

### Vinyl:

- All letter/graphics will be no less than 5-year grade vinyl, with a suggestion of using 8-year grade.
- Ensure the equipment’s surface is primed properly.

### Fonts:

- ‘Doing The Most Good’ Trajan Pro-BOLD (Open Type) Font
- “The Salvation Army” Times New Roman
- “Emergency Disaster Services” Arial Bold
- All remaining lines Arial
- All fonts CAPS

### White Space:

- The intent of graphic and lettering standards is to maximize white space to proportion on EDS vehicles. Consequently, when you see a “+” such as “EDS Logo (26”+)” consideration should be taken to use a logo 26” or larger to maximize white space. Please consider all recommendations with this in mind.

### Proportion:

- The below recommendation (in regards to “third and fourth” lines) found throughout the standard should be applied only in consideration to space allowed. Divisions have the freedom to withhold such lettering, if while condensed to proportion of upper lines it is deemed too small or difficult to read.

Side Third line: Division Designation (Font: Arial)  
Size not to exceed length of the second line if possible

\*Side Fourth line: Home City and State abbreviation (Font: Arial)  
Size not to exceed length of third line if possible





## 15' CANTEEN

### CUSTOM MOBILE FOOD EQUIPMENT

---

#### DRIVER'S SIDE

Door: DOING THE MOST GOOD logo, 2 line - stacked (20''+)

Side First line: THE SALVATION ARMY, use maximum white space (Font: Times New Roman)

Side Second line: EMERGENCY DISASTER SERVICES (Font: Arial Bold)  
Sized to fit the length of the first line

Side Third line: Division Designation (Font: Arial)  
Size not to exceed length of the second line if possible

\*Side Fourth line: Home City and State abbreviation (Font: Arial)  
Size not to exceed length of third line if possible  
\*At divisional discretion

Side: EDS Shield (26''+) to right side of lettering, use maximum white space

#### PASSENGER/CURB SIDE

Door: DOING THE MOST GOOD logo, 2 line - stacked (20''+)

Side: Graphics placed lower left or right of serving window:

Side First line: THE SALVATION ARMY, use maximum space (Font: Times New Roman)

Side Second line: EMERGENCY DISASTER SERVICES (Font: Arial Bold)  
Sized to fit the length of the first line

Side Third line: Division Designation (Font: Arial)  
Size not to exceed length of the second line if possible

\*Side Fourth line: Home City and State abbreviation (Font: Arial)  
Size not to exceed length of third line if possible  
\*At divisional discretion

Side: EDS Shield (26''+) to left or right of serving window, use maximum white space

#### FRONT

Top Banner: EMERGENCY DISASTER SERVICES, 12+ centered (Font: Arial Bold)  
EDS Shield, one on each side (12''+)

Hood: DOING THE MOST GOOD logo, single or double line stacked

Bumper: Passenger side, Unit/Divisional identification letter/number  
BLACK on chrome bumper or RED on white bumper, WHITE on black bumper

#### REAR

Top Right: Unit/Divisional identification letter/number, 2'' - 2 1/2'', based on available space

Door: EDS Shield, one on each side of door (12''+)

**ROOF**

EDS Shield (30"+), centered (optional) use maximum white space

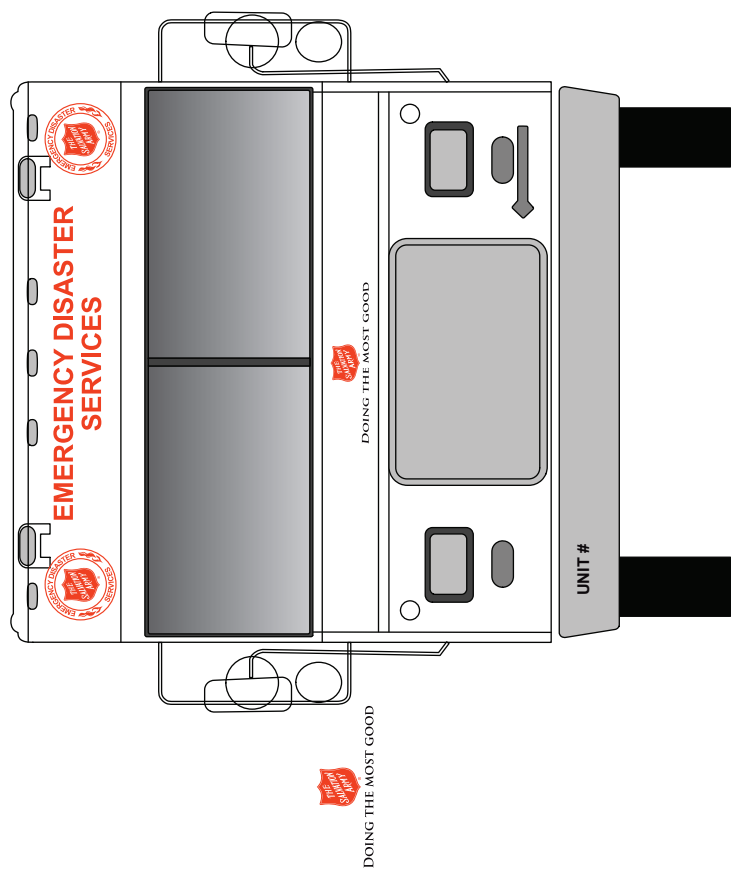
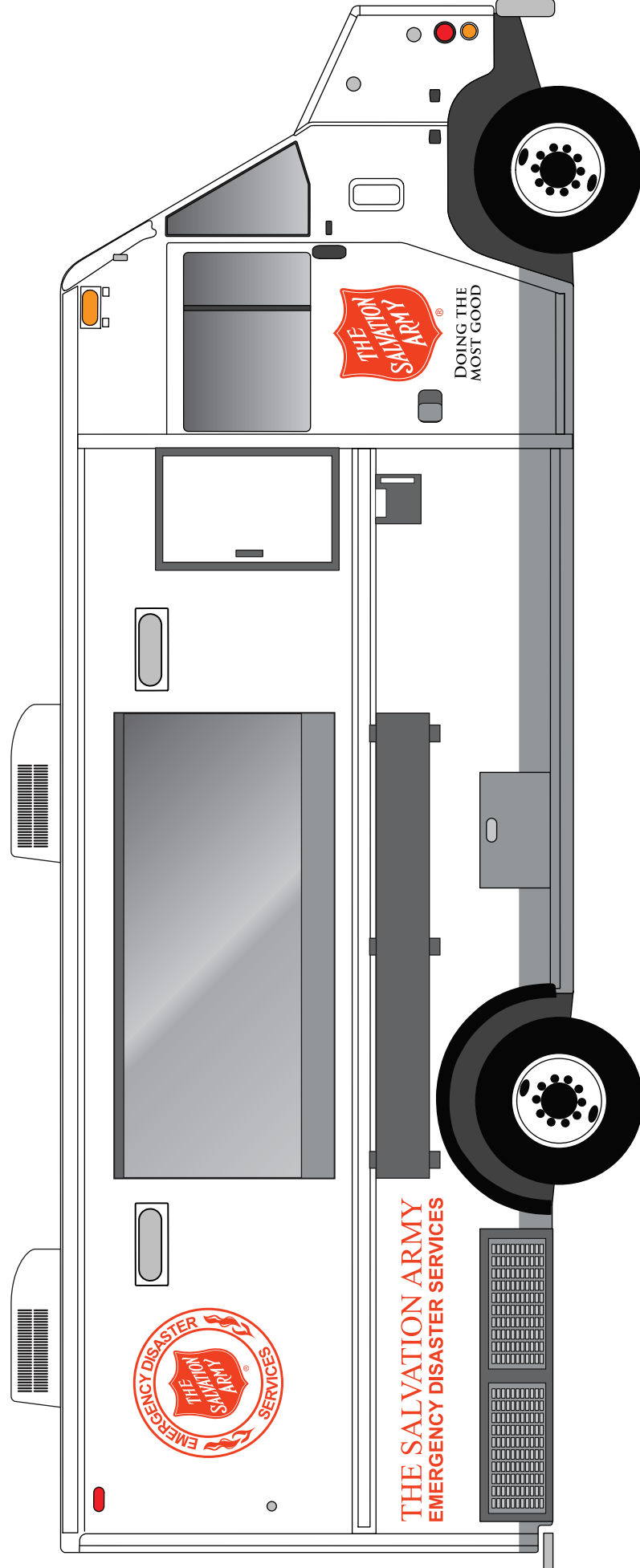
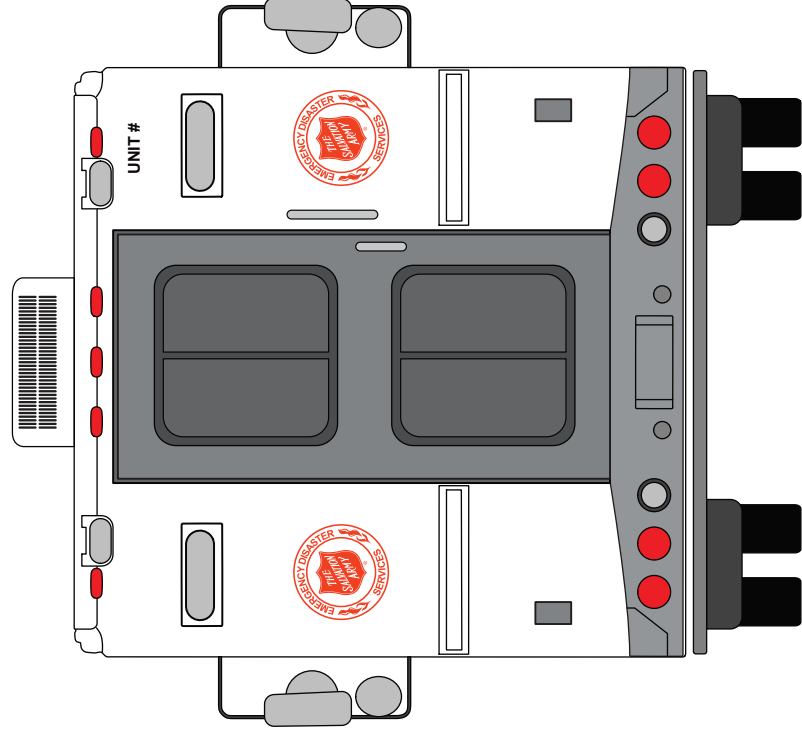
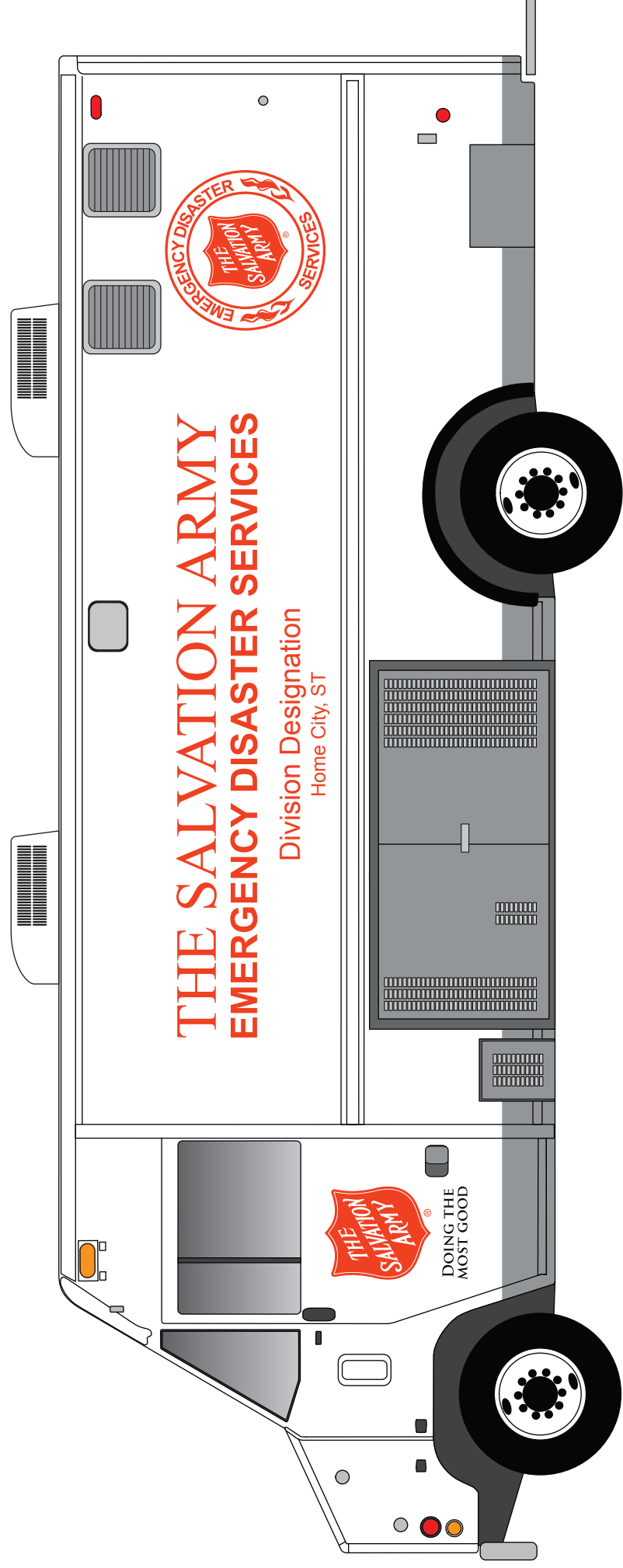

**PLEASE CHECK YOUR ART CAREFULLY**

\*NOTE: Your signature acknowledges responsibility for verifying and confirming that the dimensions and colors of the artwork are correct for the intended use. Lowen Color Graphics is not responsible for graphic replacement if the actual dimensions required are different than those listed and approved by the customer on this art rendering. This includes sizing, copy/logo placement, and overall finish. Please check carefully and advise Lowen Color Graphics of any needed graphic changes to this rendering.

This art has been prepared exclusively for our customer and may not be reproduced without written approval from Lowen Corporation. Lowen artwork remains the property of Lowen Corporation until customer purchases it or its intended products. Lowen Corporation reserves the right to bill for unreturned artwork.

Initial the appropriate line, sign and return. Revisions on artwork are subject to a fee.

\_\_\_ Art approved as is (Please review and initial)

\_\_\_ All spelling is correct

\_\_\_ All colors are correct

\_\_\_ All dimensions are correct\*

\_\_\_ Art approved with noted changes

\_\_\_ Changes indicated - prepare revised art

X

Signature

Approved signature required prior to production.

Date

Salvation Army

Shown: Custom Mobile Feeding Equipment 15' Canteen | 02 - 22 - 11 | JDK





## **18' CANTEEN**

### **CUSTOM MOBILE FOOD EQUIPMENT**

---

#### **DRIVER'S SIDE**

Door: DOING THE MOST GOOD logo, 2 line - stacked (20''+)

Side First line: THE SALVATION ARMY, use maximum white space (Font: Times New Roman)

Side Second line: EMERGENCY DISASTER SERVICES (Font: Arial Bold)  
Sized to fit the length of the first line

Side Third line: Division Designation (Font: Arial)  
Size not to exceed length of the second line if possible

\*Side Fourth line: Home City and State abbreviation (Font: Arial)  
Size not to exceed length of third line if possible  
\*At divisional discretion

Side: EDS Shield (26''+) to right side of lettering, use maximum white space

#### **PASSENGER/CURB SIDE**

Door: DOING THE MOST GOOD logo, 2 line - stacked (20''+)

Side: Graphics placed lower left or right of serving window:

Side First line: THE SALVATION ARMY, use maximum space (Font: Times New Roman)

Side Second line: EMERGENCY DISASTER SERVICES (Font: Arial Bold)  
Sized to fit the length of the first line

Side Third line: Division Designation (Font: Arial)  
Size not to exceed length of the second line if possible

\*Side Fourth line: Home City and State abbreviation (Font: Arial)  
Size not to exceed length of third line if possible  
\*At divisional discretion

Side: EDS Shield (26''+) to left **or** right of serving window, use maximum white space

#### **FRONT**

Top Banner: EMERGENCY DISASTER SERVICES, 12+ centered (Font: Arial Bold)  
EDS Shield, one on each side (12''+)

Hood: DOING THE MOST GOOD logo, single or double line stacked

Bumper: Passenger side, Unit/Divisional identification letter/number  
BLACK on chrome bumper or RED on white bumper, WHITE on black bumper

#### **REAR**

Top Right: Unit/Divisional identification letter/number, 2'' - 2 1/2'', based on available space

Door: EDS Shield, one on each side of door (12''+)

**ROOF**

EDS Shield (30"+), centered (optional) use maximum white space

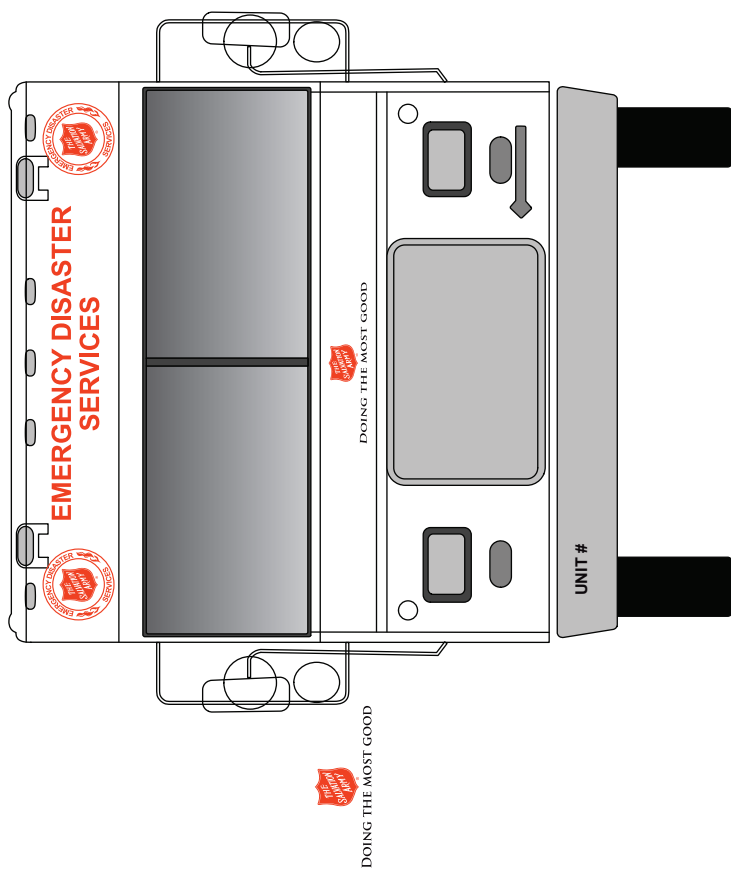
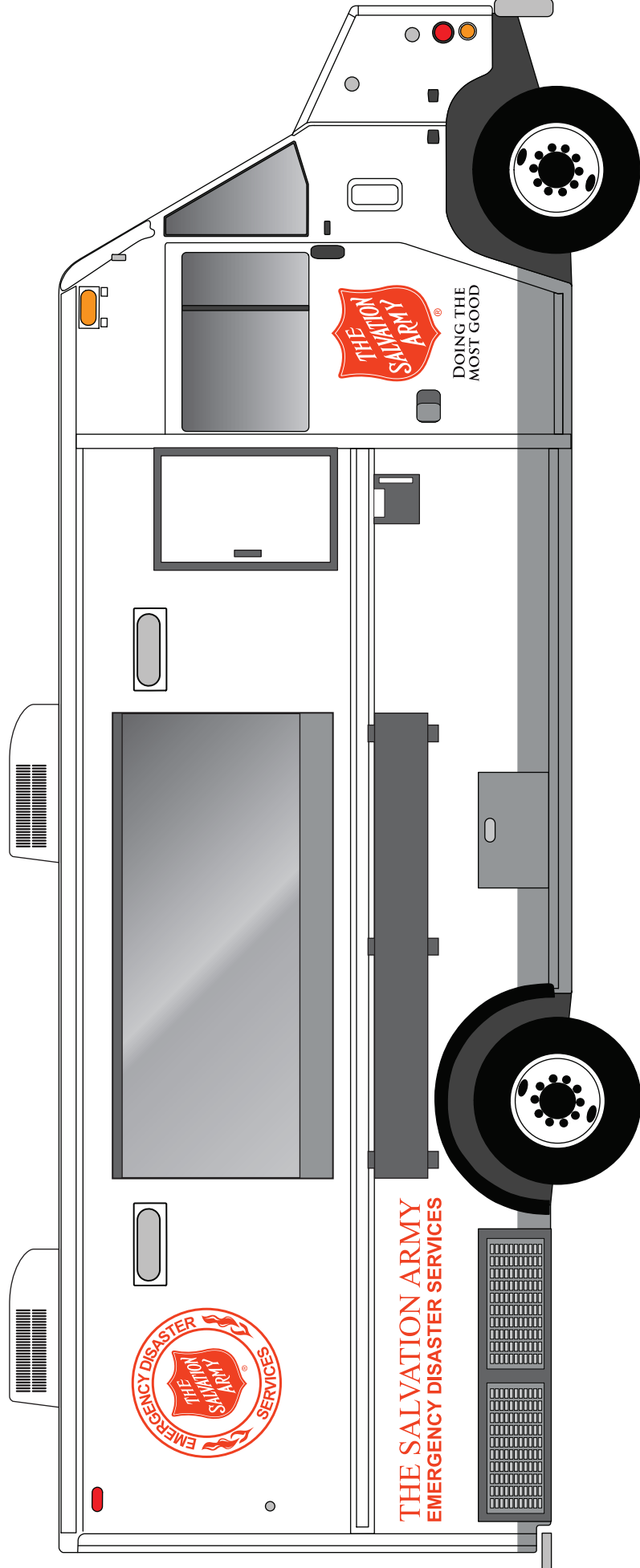
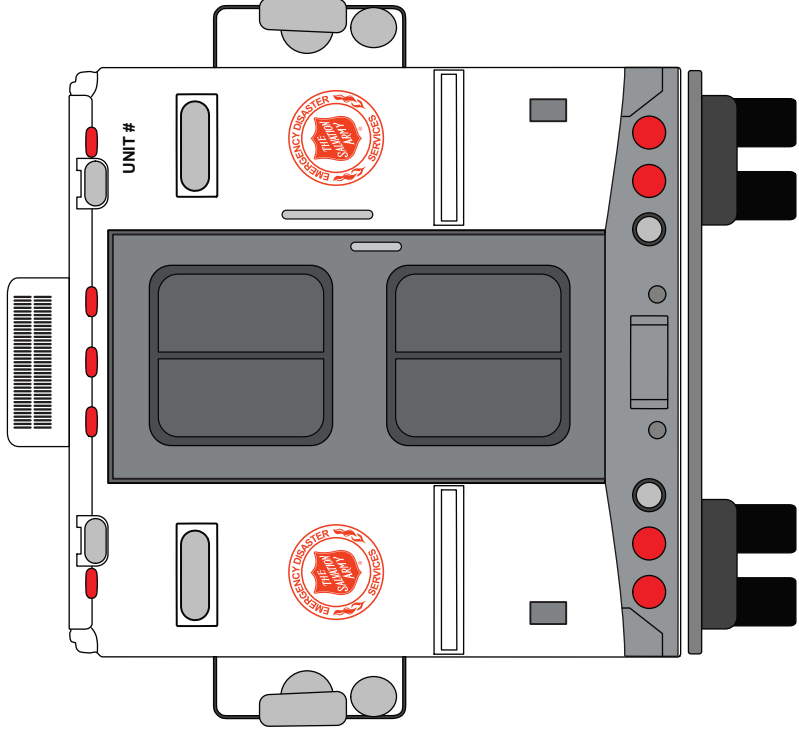
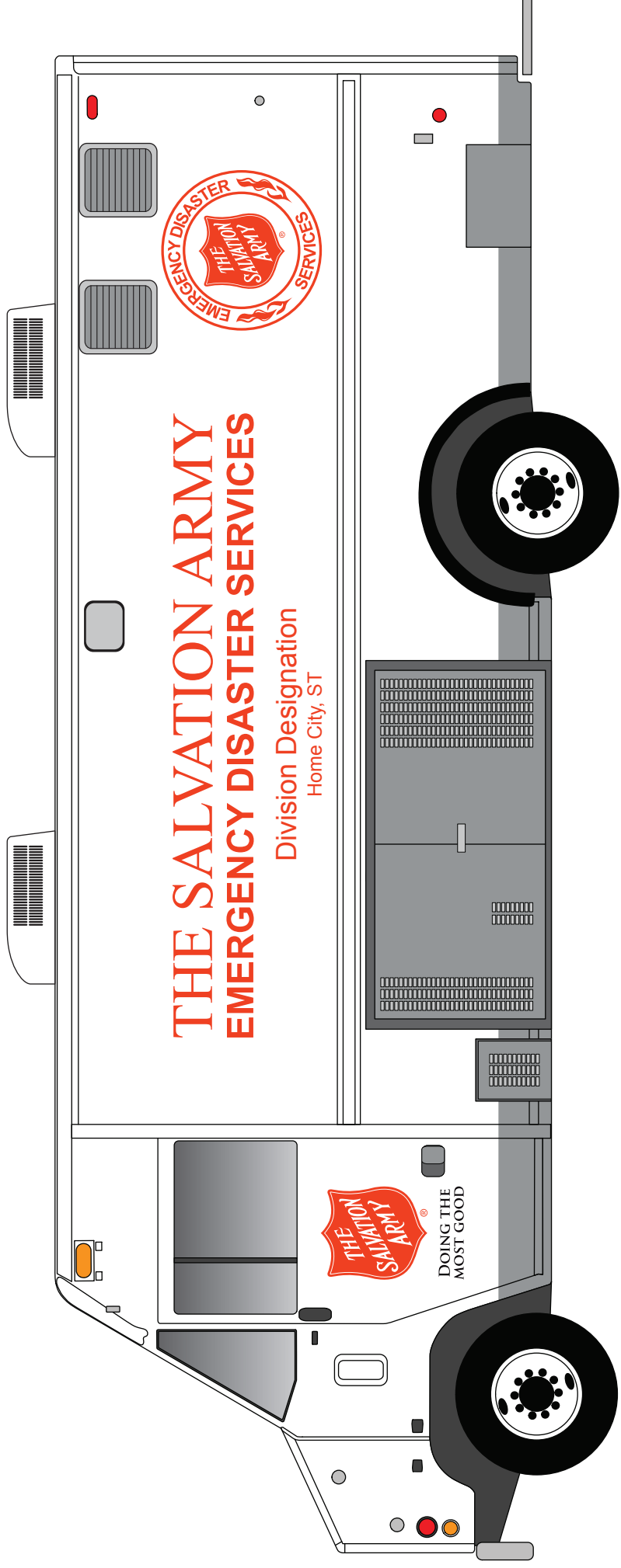

**PLEASE CHECK YOUR ART CAREFULLY**

\*\*NOTE: Your signature acknowledges responsibility for verifying and confirming that the dimensions and colors of the artwork are correct for the intended use. Lowen Color Graphics is not responsible for graphic replacement if the actual dimensions required are different than those listed and approved by the customer on this art rendering. This includes sizing, copy/logo placement, and overall finish. Please check carefully and advise Lowen Color Graphics of any needed graphic changes to this rendering.

This art has been prepared exclusively for our customer and may not be reproduced without written approval from Lowen Corporation. Lowen artwork remains the property of Lowen Corporation until customer purchases it or its intended products. Lowen Corporation reserves the right to bill for unreturned artwork.

Initial the appropriate line, sign and return. Revisions on artwork are subject to a fee.

\_\_\_ Art approved as is (Please review and initial)

\_\_\_ All spelling is correct

\_\_\_ All colors are correct

\_\_\_ All dimensions are correct\*

\_\_\_ Art approved with noted changes

\_\_\_ Changes indicated - prepare revised art

X

Signature

Approved signature required prior to production.

Date

Salvation Army

Shown: Custom Mobile Feeding Equipment 18' Canteen | 02 - 22 - 11 | JDK







## 12' DRU

### KEYSTONE COACHWORKS

---

#### DRIVER'S SIDE

- Door: DOING THE MOST GOOD logo, 2 line - stacked (20''+)
- Side First line: THE SALVATION ARMY, use maximum white space (Font: Times New Roman)
- Side Second line: EMERGENCY DISASTER SERVICES (Font: Arial Bold)  
Sized to fit the length of the first line
- Side Third line: Division Designation (Font: Arial)  
Size not to exceed length of the second line if possible
- \*Side Fourth line: Home City and State abbreviation (Font: Arial)  
Size not to exceed length of third line if possible  
\*At divisional discretion
- Sides: EDS Shield, on each side of lettering, (26''+) use maximum white space

#### PASSENGER/CURB SIDE

- Door: DOING THE MOST GOOD logo, 2 line - stacked (20''+)
- Side: Graphics placed lower left or right of serving window:
- Side First line: EMERGENCY DISASTER SERVICES (Font: Arial Bold)  
Above serving window
- Side Second line: THE SALVATION ARMY (Font: Times New Roman)  
Below serving window
- Side Third line: Division Designation (Font: Arial)  
Size not to exceed length of the second line if possible
- \*Side Fourth line: Home City and State abbreviation (Font: Arial)  
Size not to exceed length of third line if possible  
\*At divisional discretion
- Side Rear: EDS Shield (26''+) to left **and** right of serving window, use maximum white space

#### FRONT

- Top Banner: EMERGENCY DISASTER SERVICES, 12+ centered (Font: Arial Bold)  
EDS Shield, one on each side (12''+)
- Hood: DOING THE MOST GOOD logo, single or double line stacked
- Bumper: Passenger side, Unit/Divisional identification letter/number  
2'' - 2 1/2'', based on available space  
BLACK on chrome bumper, or RED on white bumper, WHITE on black bumper

**REAR**

Top Right: Unit/Divisional identification letter/number  
2" - 2 ½", based on available space

White Doors: "EMERGENCY" above window (Font: Arial Bold)  
"DISASTER SERVICES" below window (Font: Arial Bold)

Sides: EDS Shield, one on each side of door (12"+)

**ROOF**

EDS Logo (30"+), centered (optional) use maximum white space

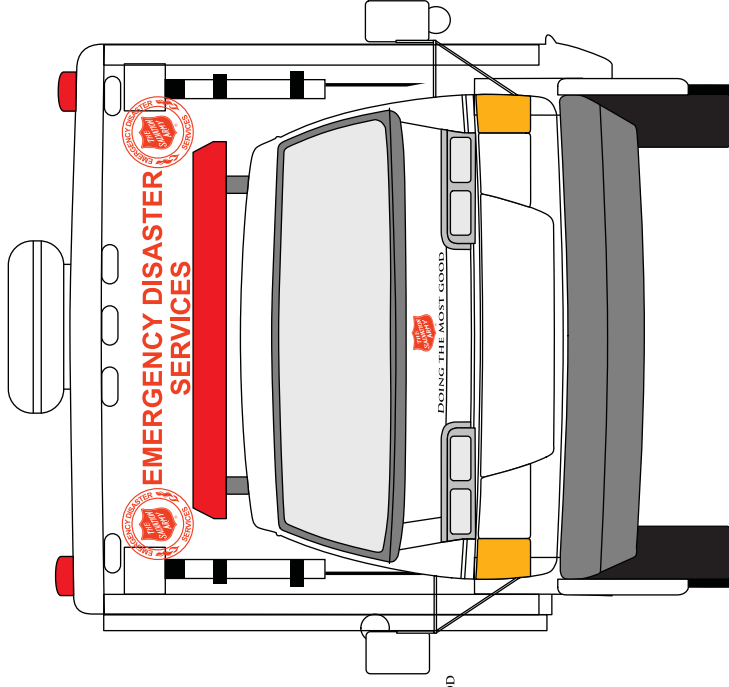
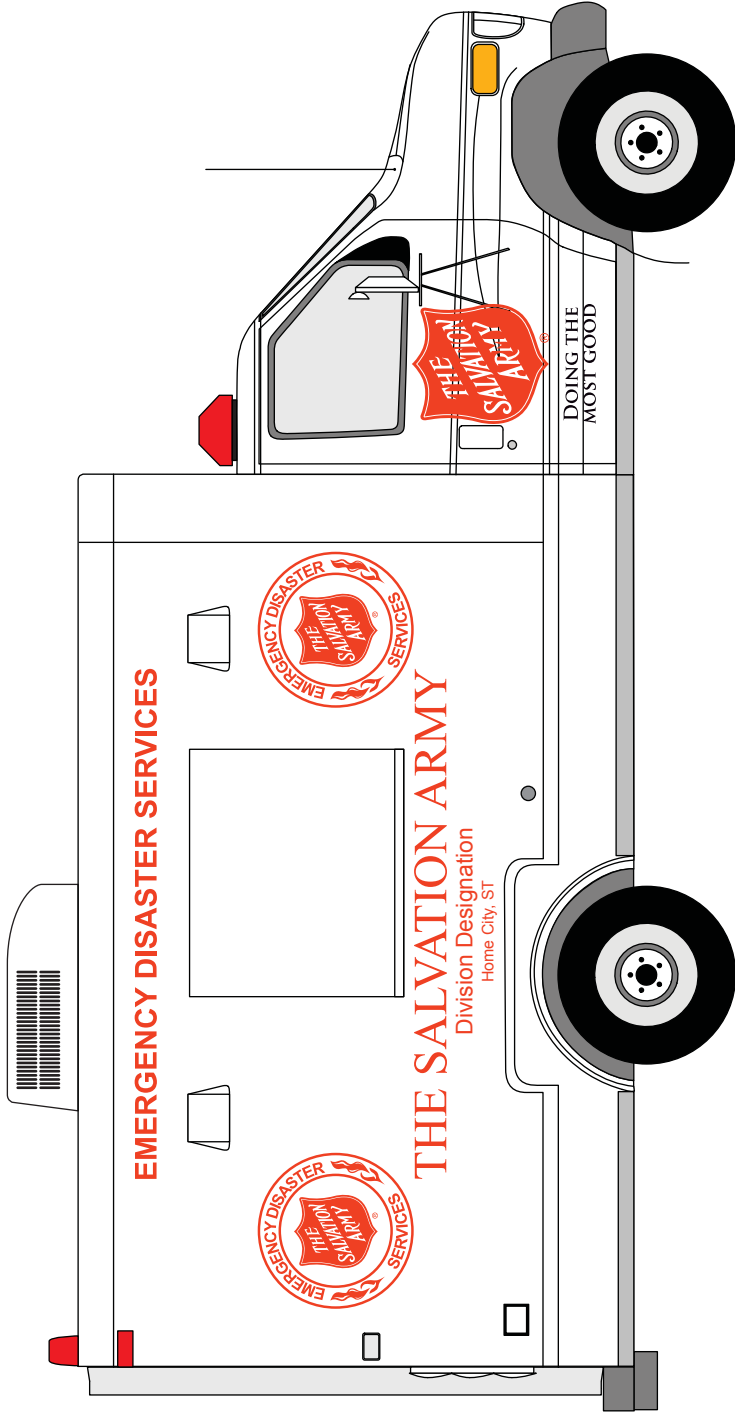
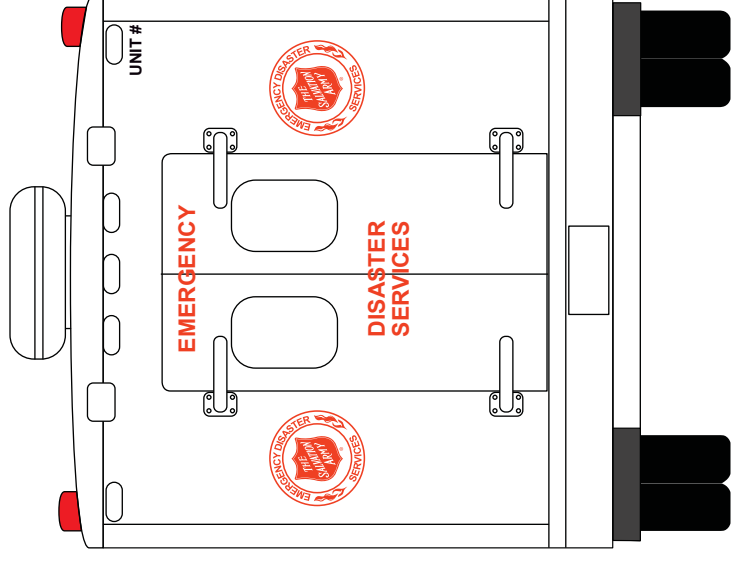
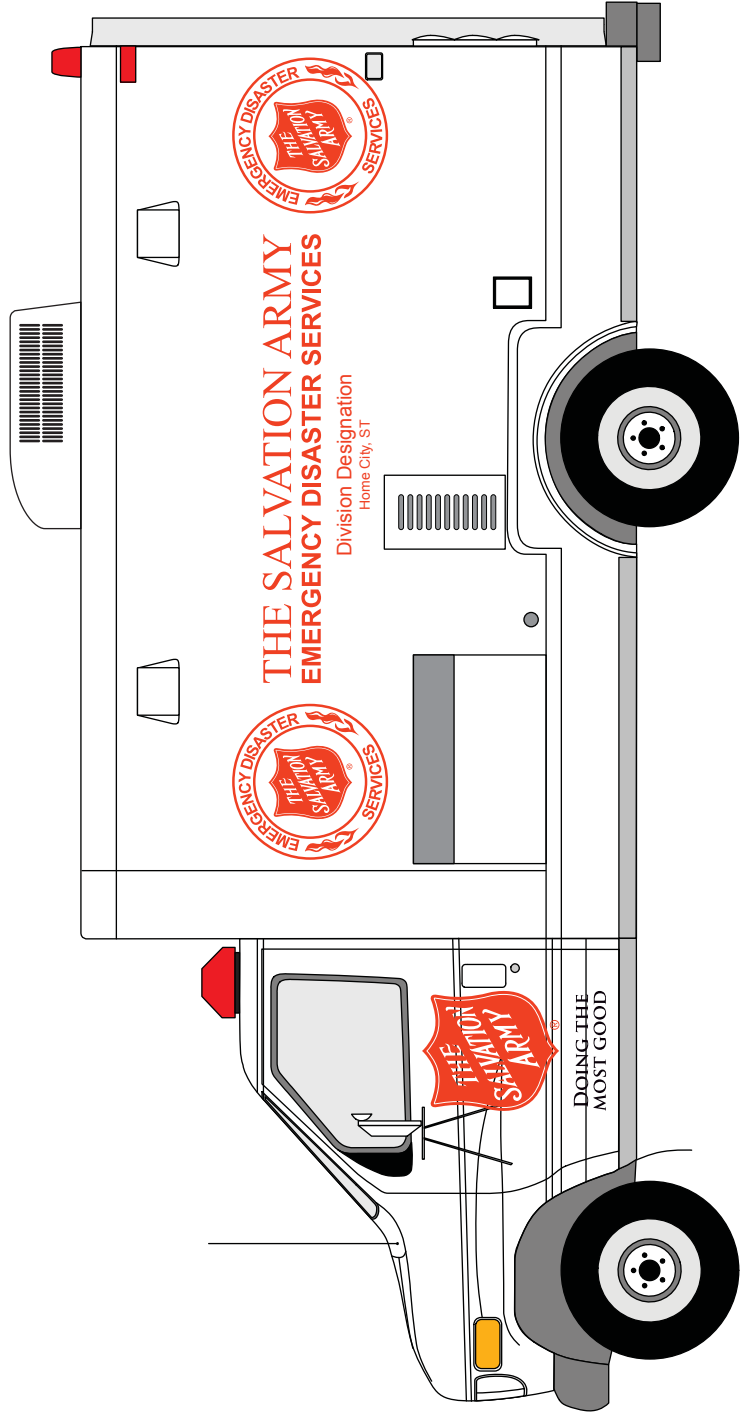

**PLEASE CHECK YOUR ART CAREFULLY**

\*NOTE: Your signature acknowledges responsibility for verifying and confirming that the dimensions and colors of the artwork are correct for the intended use. Lowen Color Graphics is not responsible for graphic replacement if the actual dimensions required are different than those listed and approved by the customer on this art rendering. This includes sizing, copy/logo placement, and overall finish. Please check carefully and advise Lowen Color Graphics of any needed graphic changes to this rendering.

This art has been prepared exclusively for our customer and may not be reproduced without written approval from Lowen Corporation. Lowen artwork remains the property of Lowen Corporation until customer purchases it or its intended products. Lowen Corporation reserves the right to bill for unreturned artwork.

Initial the appropriate line, sign and return. Revisions on artwork are subject to a fee.

\_\_\_ Art approved as is (Please review and initial)

\_\_\_ All spelling is correct

\_\_\_ All colors are correct

\_\_\_ All dimensions are correct\*

\_\_\_ Art approved with noted changes

\_\_\_ Changes indicated - prepare revised art

X

Signature

Approved signature required prior to production.

Signature

Approved signature required prior to production.

Date

Salvation Army

Shown: Keystone Coachworks 12' DRU | 02 - 22 - 11

JDK



## 16' DRU

### KEYSTONE COACHWORKS

---

#### DRIVER'S SIDE

- Door: DOING THE MOST GOOD logo, 2 line - stacked (20''+)
- Side First line: THE SALVATION ARMY, use maximum white space (Font: Times New Roman)
- Side Second line: EMERGENCY DISASTER SERVICES (Font: Arial Bold)  
Sized to fit the length of the first line
- Side Third line: Division Designation (Font: Arial)  
Size not to exceed length of the second line if possible
- \*Side Fourth line: Home City and State abbreviation (Font: Arial)  
Size not to exceed length of third line if possible  
\*At divisional discretion
- Sides: EDS Shield, on each side of lettering, (26''+) use maximum white space

#### PASSENGER/CURB SIDE

- Door: DOING THE MOST GOOD logo, 2 line - stacked (20''+)
- Side: Graphics placed lower left or right of serving window:
- Side First line: EMERGENCY DISASTER SERVICES (Font: Arial Bold)  
Above serving window
- Side Second line: THE SALVATION ARMY, use maximum white space (Font: Times New Roman)  
Below serving window
- Side Third line: Division Designation (Font: Arial)  
Size not to exceed length of the second line if possible
- \*Side Fourth line: Home City and State abbreviation (Font: Arial)  
Size not to exceed length of third line if possible  
\*At divisional discretion
- Side Rear: EDS Shield (26''+) to left **and** right of serving window, use maximum white space

#### FRONT

- Top Banner: EMERGENCY DISASTER SERVICES, 12+ centered (Font: Arial Bold)  
EDS Shield, one on each side (12''+)
- Hood: DOING THE MOST GOOD logo, single or double line stacked
- Bumper: Passenger side, Unit/Divisional identification letter/number  
BLACK on chrome bumper or RED on white bumper, WHITE on black bumper

**REAR**

- Top Right: Unit/Divisional identification letter/number  
2" - 2 ½", based on available space
- White Doors: "EMERGENCY" above window (Font: Arial Bold)  
"DISASTER SERVICES" below window (Font: Arial Bold)
- Sides: EDS Shield, one on each side of door (12"+)
- ROOF** EDS Logo (30"+), centered (optional) use maximum white space

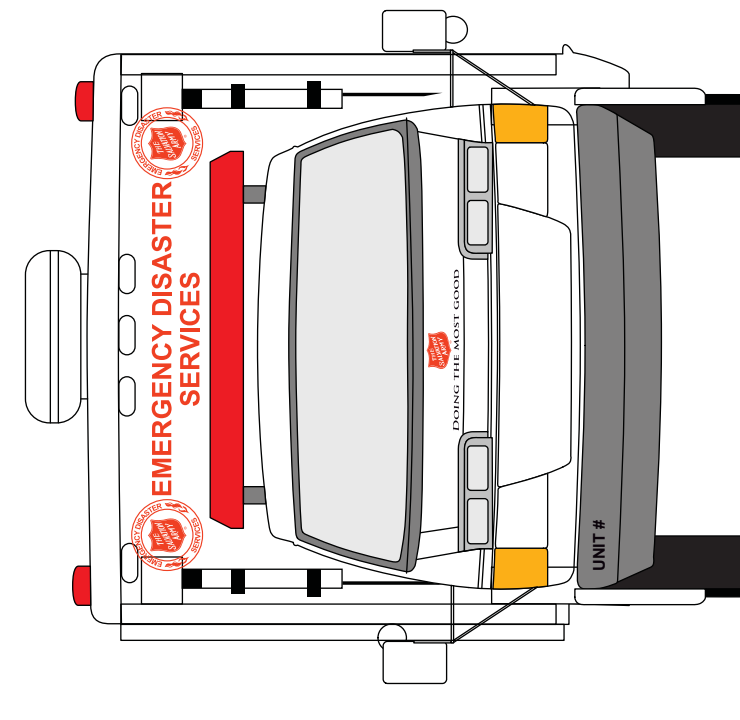
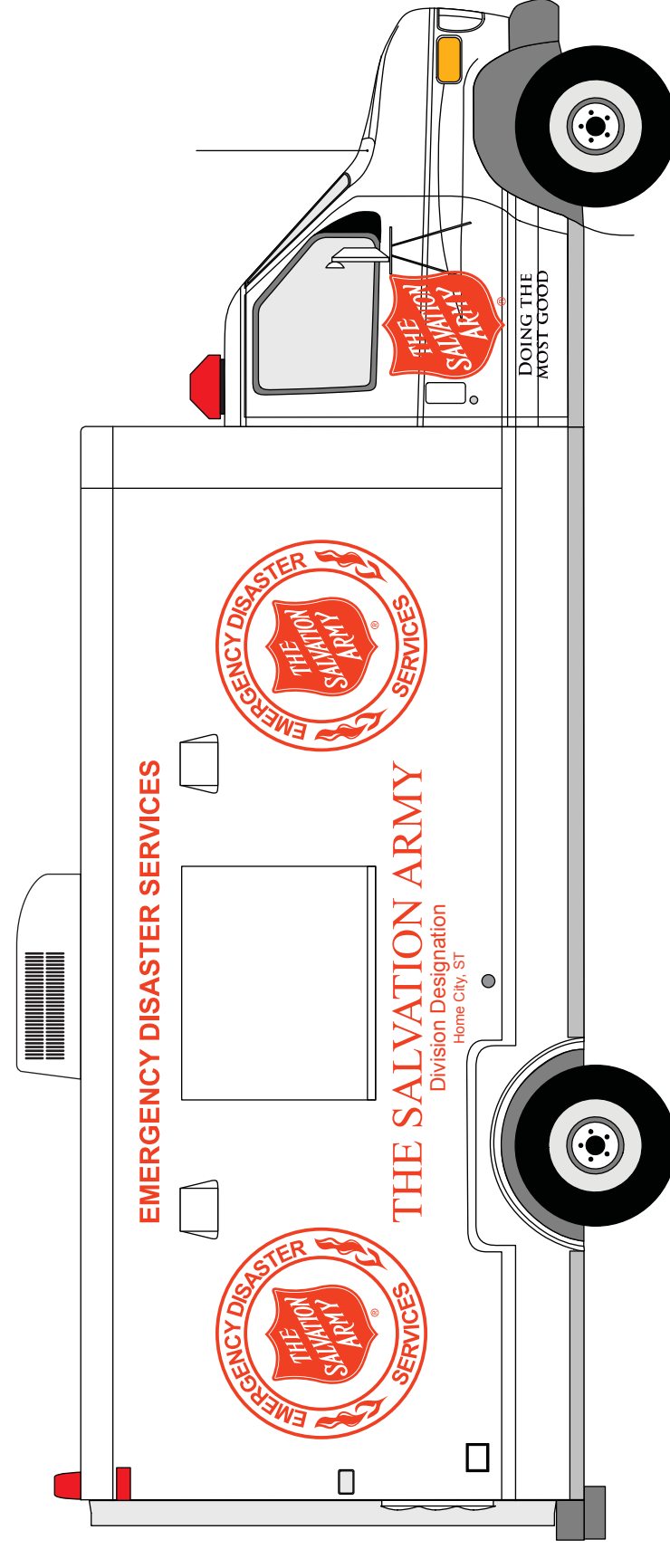
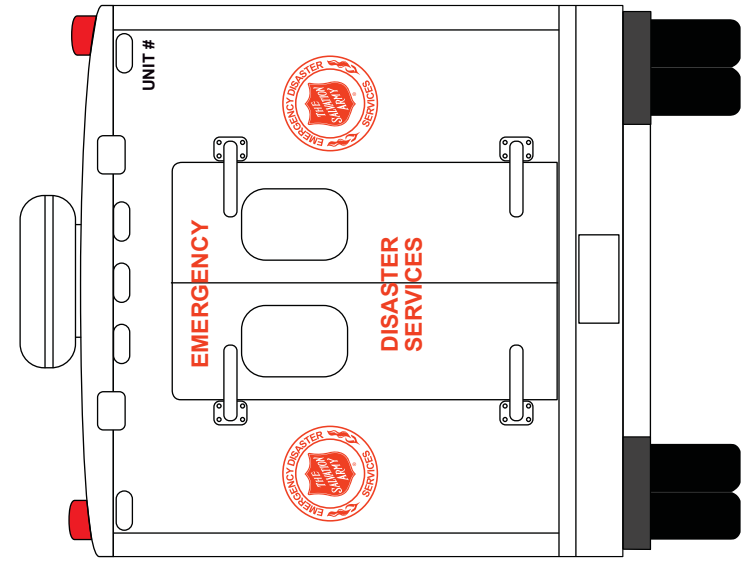
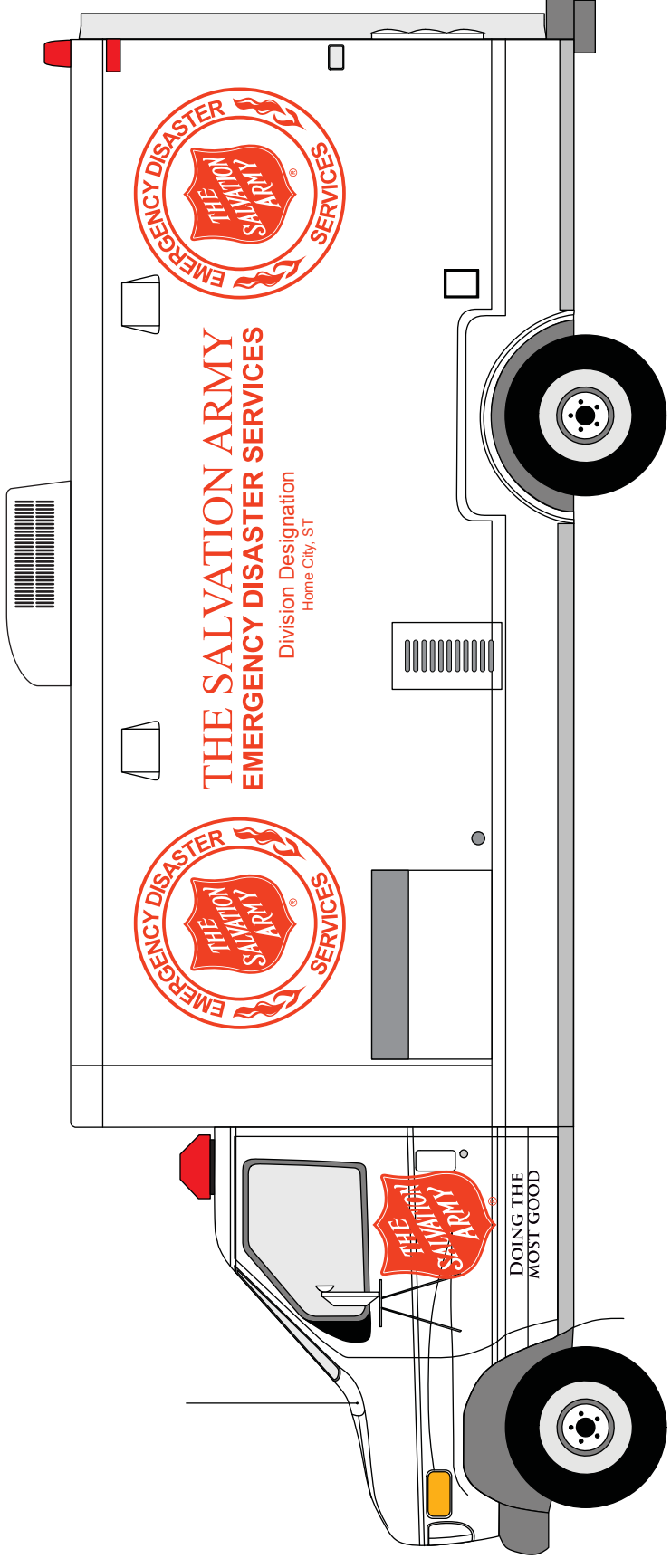

DOING THE MOST GOOD

**PLEASE CHECK YOUR ART CAREFULLY**

\*NOTE: Your signature acknowledges responsibility for verifying and confirming that the dimensions and colors of the artwork are correct for the intended use. Lowen Color Graphics is not responsible for graphic replacement if the actual dimensions required are different than those listed and approved by the customer on this art rendering. This includes sizing, copy/logo placement, and overall finish. Please check carefully and advise Lowen Color Graphics of any needed graphic changes to this rendering.

This art has been prepared exclusively for our customer and may not be reproduced without written approval from Lowen Corporation. Lowen artwork remains the property of Lowen Corporation until customer purchases it or its intended products. Lowen Corporation reserves the right to bill for unreturned artwork.

Initial the appropriate line, sign and return. Revisions on artwork are subject to a fee.

- Art approved as is (Please review and initial)
- All spelling is correct
- All colors are correct
- All dimensions are correct\*
- Art approved with noted changes
- Changes indicated - prepare revised art

X  
Signature \_\_\_\_\_ Date \_\_\_\_\_  
Approved signature required prior to production.

Shown: Keystone Coachworks 16' DRU | 02 - 22 - 11 | JDK  
Salvation Army







## CATERING TRUCK

---

### DRIVER'S SIDE

Door: DOING THE MOST GOOD logo, 2 line - stacked (20"+)  
Side First line: THE SALVATION ARMY, use maximum white space (Font: Times New Roman)  
Side Second line: EMERGENCY DISASTER SERVICES (Font: Arial Bold)  
Sized to fit the length of the first line  
Side Third line: Division Designation (Font: Arial)  
Size not to exceed length of the second line if possible  
\*Side Fourth line: Home City and State abbreviation (Font: Arial)  
Size not to exceed length of third line if possible  
\*At divisional discretion  
Side: EDS Shield to left **and** right of lettering, use maximum white space

### PASSENGER/CURB SIDE

Door: DOING THE MOST GOOD logo, 2 line - stacked (20"+)  
Side First line: THE SALVATION ARMY, use maximum white space (Font: Times New Roman)  
Side Second line: EMERGENCY DISASTER SERVICES (Font: Arial Bold)  
Sized to fit the length of the first line  
Side Third line: Division Designation (Font: Arial)  
Size not to exceed length of the second line if possible  
\*Side Fourth line: Home City and State abbreviation (Font: Arial)  
Size not to exceed length of third line if possible  
\*At divisional discretion  
Side: EDS Shield (26+) to left of lettering, use maximum white space

### FRONT

Hood: EDS Shield, centered  
Bumper: Passenger side, Unit/Divisional identification letter/number  
BLACK on chrome bumper, or RED on white bumper, WHITE on black bumper

### REAR

Rear: EDS Shield centered  
First line: "EMERGENCY" below EDS Shield (Font: Arial Bold)  
Second line: "DISASTER SERVICES" below Emergency (Font: Arial Bold)  
Top Right: Unit/Divisional identification letter/number, 2" - 2 1/2", based on available space



Catering Truck Driver's Side



Catering Truck Passenger's Side





Catering Truck Rear





## **UTILITY / CARGO TRAILER**

---

### **DRIVER'S SIDE**

Side First line: THE SALVATION ARMY, use maximum white space (Font: Times New Roman)  
Side Second line: EMERGENCY DISASTER SERVICES (Font: Arial Bold)  
Sized to fit the length of the first line  
Side Third line: Division Designation (Font: Arial)  
Size not to exceed length of the second line if possible  
\*Side Fourth line: Home City and State abbreviation (Font: Arial)  
Size not to exceed length of third line if possible  
\*At divisional discretion  
Front: EDS Shield (24+) on each side of lettering, use maximum white space

### **PASSENGER/CURB SIDE**

Side First line: THE SALVATION ARMY, use maximum white space (Font: Times New Roman)  
Side Second line: EMERGENCY DISASTER SERVICES (Font: Arial Bold)  
Sized to fit the length of the first line  
Side Third line: Division Designation (Font: Arial)  
Size not to exceed length of the second line if possible  
\*Side Fourth line: Home City and State abbreviation (Font: Arial)  
Size not to exceed length of third line if possible  
\*At divisional discretion  
Front: EDS Shield (24+) on each side of lettering, use maximum white space

### **FRONT**

Hood: "DOING THE MOST GOOD" logo, centered  
Top Left: Unit/Divisional identification letter/number  
2" - 3" based on available space

### **REAR**

Door(s): EDS Shield (24+) use maximum white space  
Top, center on each door  
Top Right: Unit/Divisional identification letter/number  
2" - 3" based on available space





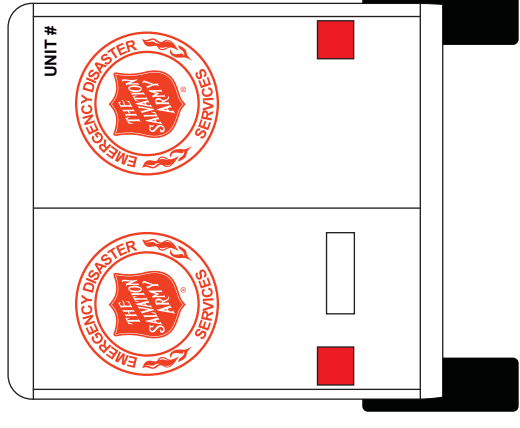
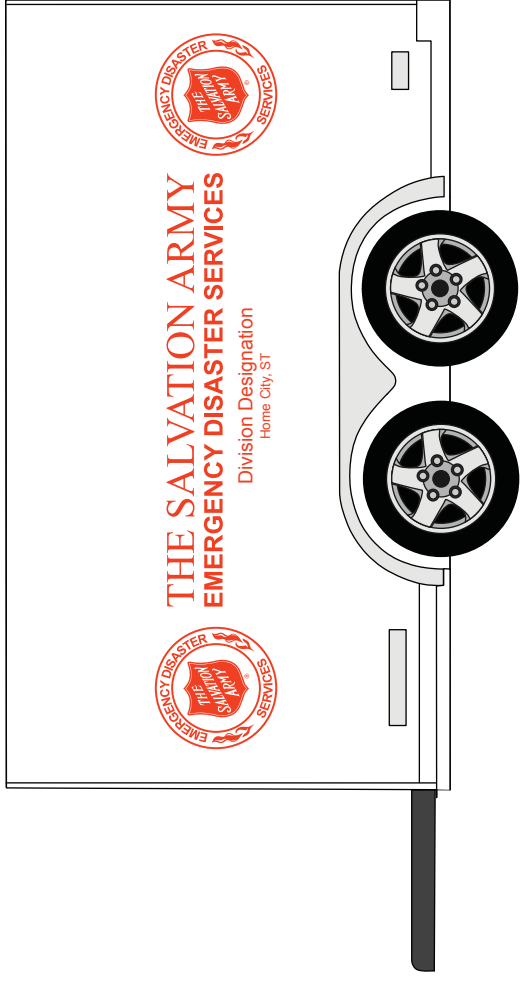

**PLEASE CHECK YOUR ART CAREFULLY**

\*\*NOTE: Your signature acknowledges responsibility for verifying and confirming that the dimensions and colors of the artwork are correct for the intended use. Lowen Color Graphics is not responsible for graphic replacement if the actual dimensions required are different than those listed and approved by the customer on this art rendering. This includes sizing, copy/logo placement, and overall finish. Please check carefully and advise Lowen Color Graphics of any needed graphic changes to this rendering.

This art has been prepared exclusively for our customer and may not be reproduced without written approval from Lowen Corporation. Lowen artwork remains the property of Lowen Corporation until customer purchases it or its intended products. Lowen Corporation reserves the right to bill for unreturned artwork.

Initial the appropriate line, sign and return. Revisions on artwork are subject to a fee.

\_\_\_ Art approved as is (Please review and initial)

\_\_\_ All spelling is correct

\_\_\_ All colors are correct

\_\_\_ All dimensions are correct\*

\_\_\_ Art approved with noted changes

\_\_\_ Changes indicated - prepare revised art

X

Signature

Approved signature required prior to production.

Date

Salvation Army

Shown: Cargo/Utility Trailer | 2 - 22 - 11

JDK



## **TRAILER CANTEENS**

---

### **DRIVER'S SIDE**

Above Window: EMERGENCY DISASTER SERVICES (Font: Arial Bold)

Below Window:

First line: THE SALVATION ARMY, use maximum white space (Font: Times New Roman)

Second line: EMERGENCY DISASTER SERVICES (Font: Arial Bold)  
Sized to fit the length of the first line

Side Third line: Division Designation (Font: Arial)  
Size not to exceed length of the second line if possible

\*Side Fourth line: Home City and State abbreviation (Font: Arial)  
Size not to exceed length of third line if possible  
\*At divisional discretion

Side: EDS Shield (24+) centered to the side of window, use maximum white space

### **PASSENGER'S SIDE**

Above Window: EMERGENCY DISASTER SERVICES (Font: Arial Bold)

Below Window:

First line: THE SALVATION ARMY, use maximum white space (Font: Times New Roman)

Second line: EMERGENCY DISASTER SERVICES (Font: Arial Bold)  
Sized to fit the length of the first line

Side Third line: Division Designation (Font: Arial)  
Size not to exceed length of the second line if possible

\*Side Fourth line: Home City and State abbreviation (Font: Arial)  
Size not to exceed length of third line if possible  
\*At divisional discretion

Side: EDS Shield (24+) centered to the side of window, use maximum white space

### **FRONT:**

Door(s): "DOING THE MOST GOOD" logo, 2-line, stacked, centered

Top Left: Unit/Divisional identification letter/number, 2" - 3" based on available space

### **REAR:**

Back: EDS Shield (24+) centered, use maximum white space

Top Right: Unit/Divisional identification letter/number, 2" - 3" based on available space



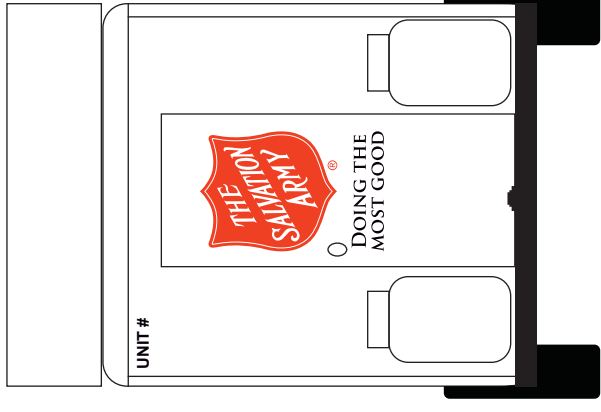
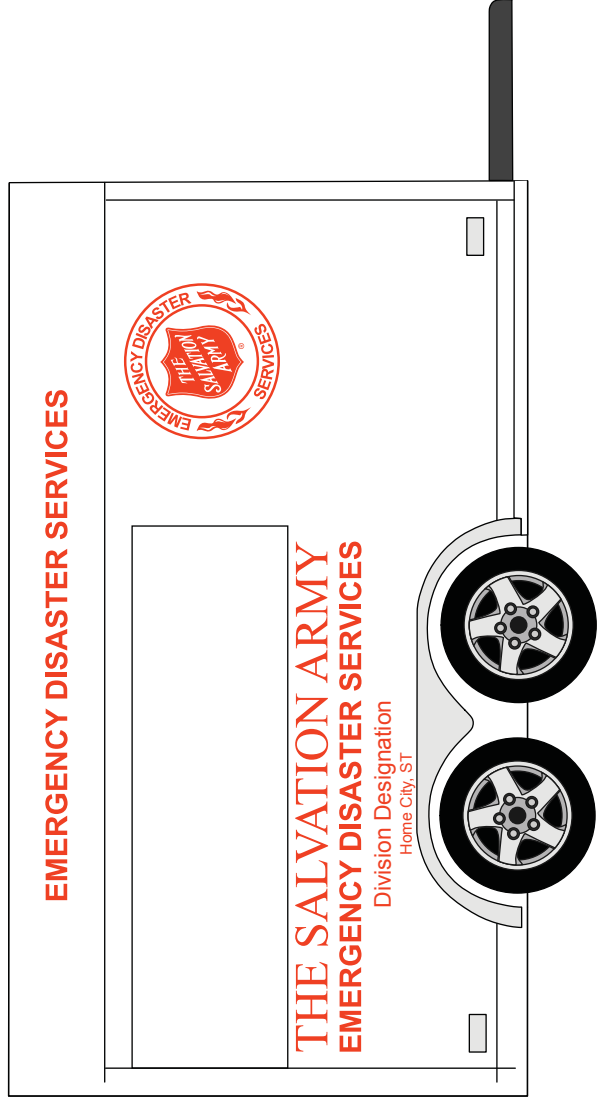
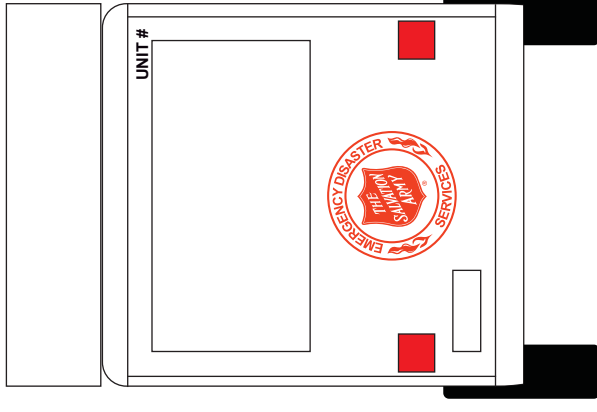
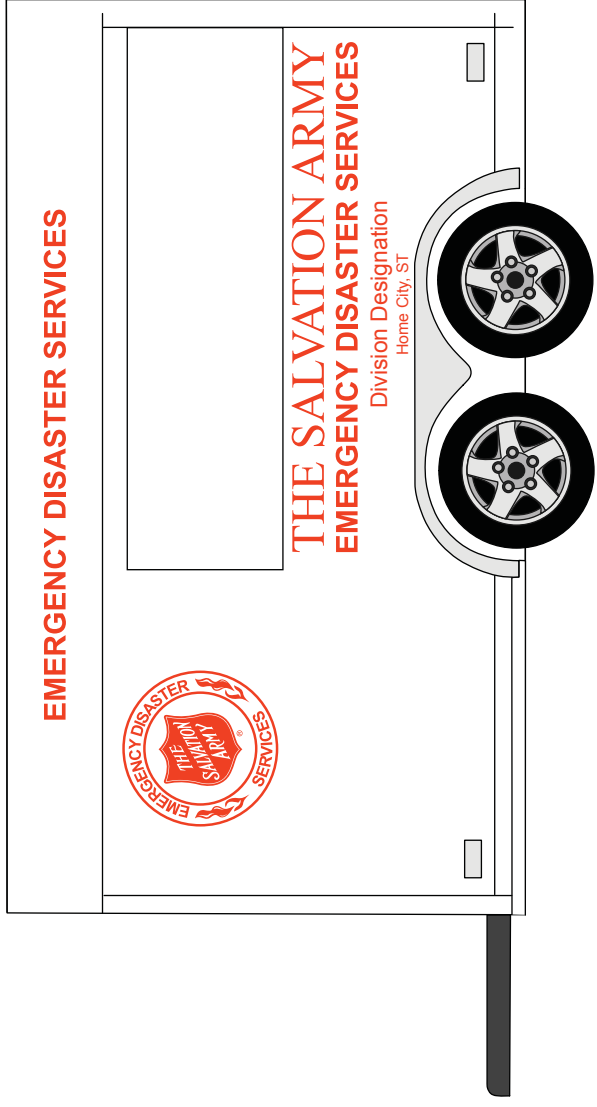

**PLEASE CHECK YOUR ART CAREFULLY**

\*\*NOTE: Your signature acknowledges responsibility for verifying and confirming that the dimensions and colors of the artwork are correct for the equipment and the intended use. Lowen Color Graphics is not responsible for graphic replacement if the actual dimensions required are different than those listed and approved by the customer on this art rendering. This includes sizing, copy/logo placement, and overall finish. Please check carefully and advise Lowen Color Graphics of any needed graphic changes to this rendering.

This art has been prepared exclusively for our customer and may not be reproduced without written approval from Lowen Corporation. Lowen artwork remains the property of Lowen Corporation until customer purchases it or its intended products. Lowen Corporation reserves the right to bill for unreturned artwork.

Initial the appropriate line, sign and return. Revisions on artwork are subject to a fee.

\_\_\_ Art approved as is (Please review and initial)

\_\_\_ All spelling is correct

\_\_\_ All colors are correct

\_\_\_ All dimensions are correct\*

\_\_\_ Art approved with noted changes

\_\_\_ Changes indicated - prepare revised art

X

Signature

Approved signature required prior to production.

Date

Salvation Army

Shown: Trailer Canteen | 02 - 22 - 11 | JDK



## **BOX TRUCK**

---

### **DRIVER'S SIDE**

Door:	EDS Shield (22") use maximum white space
Side First line:	THE SALVATION ARMY, use maximum white space (Font: Times New Roman)
Side Second line:	EMERGENCY DISASTER SERVICES (Font: Arial Bold) Sized to fit the length of the first line
Side Third line:	Division Designation (Font: Arial) Size not to exceed length of the second line if possible
*Side Fourth line:	Home City and State abbreviation (Font: Arial) Size not to exceed length of third line if possible *At divisional discretion
Side:	EDS Shield (26"+) on each side of lettering, use maximum white space
Bottom:	Solid, red, reflective horizontal stripe (6")

### **PASSENGER/CURB SIDE**

Door:	EDS Shield (22" or use maximum white space)
Side First line:	THE SALVATION ARMY, use maximum white space (Font: Times New Roman)
Side Second line:	EMERGENCY DISASTER SERVICES (Font: Arial Bold) Sized to fit the length of the first line
Side Third line:	Division Designation (Font: Arial) Size not to exceed length of the second line if possible
*Side Fourth line:	Home City and State abbreviation (Font: Arial) Size not to exceed length of third line if possible *At divisional discretion
Side:	EDS Shield (26"+) on each side of lettering, use maximum white space
Bottom:	Solid, red, reflective horizontal stripe (6")

### **FRONT**

Top Banner:	At divisional discretion
Hood:	EDS Shield, centered (12"+) use maximum white space
Bumper:	Passenger side, Unit/Divisional identification letter/number BLACK on chrome bumper or RED on white bumper, WHITE on black bumper

### **REAR**

*continued on back*

**REAR**

Top Right: Unit/Divisional identification letter/number, 2" - 2 ½", based on available space  
Door: EDS Shield centered above red stripe  
Bottom: Solid, red, reflective horizontal stripe (6")

**EXCEPTIONS**

Trailers assigned as "Canteen Support" do not need reflective, horizontal stripe



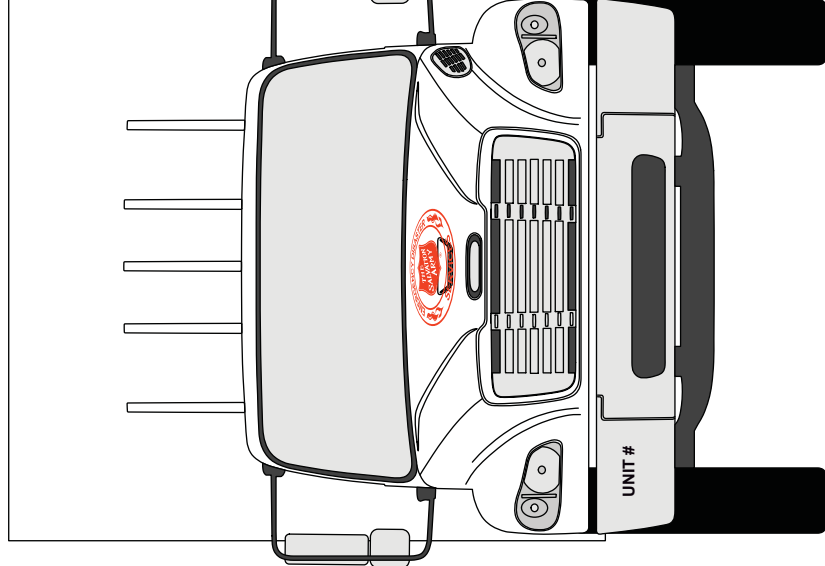
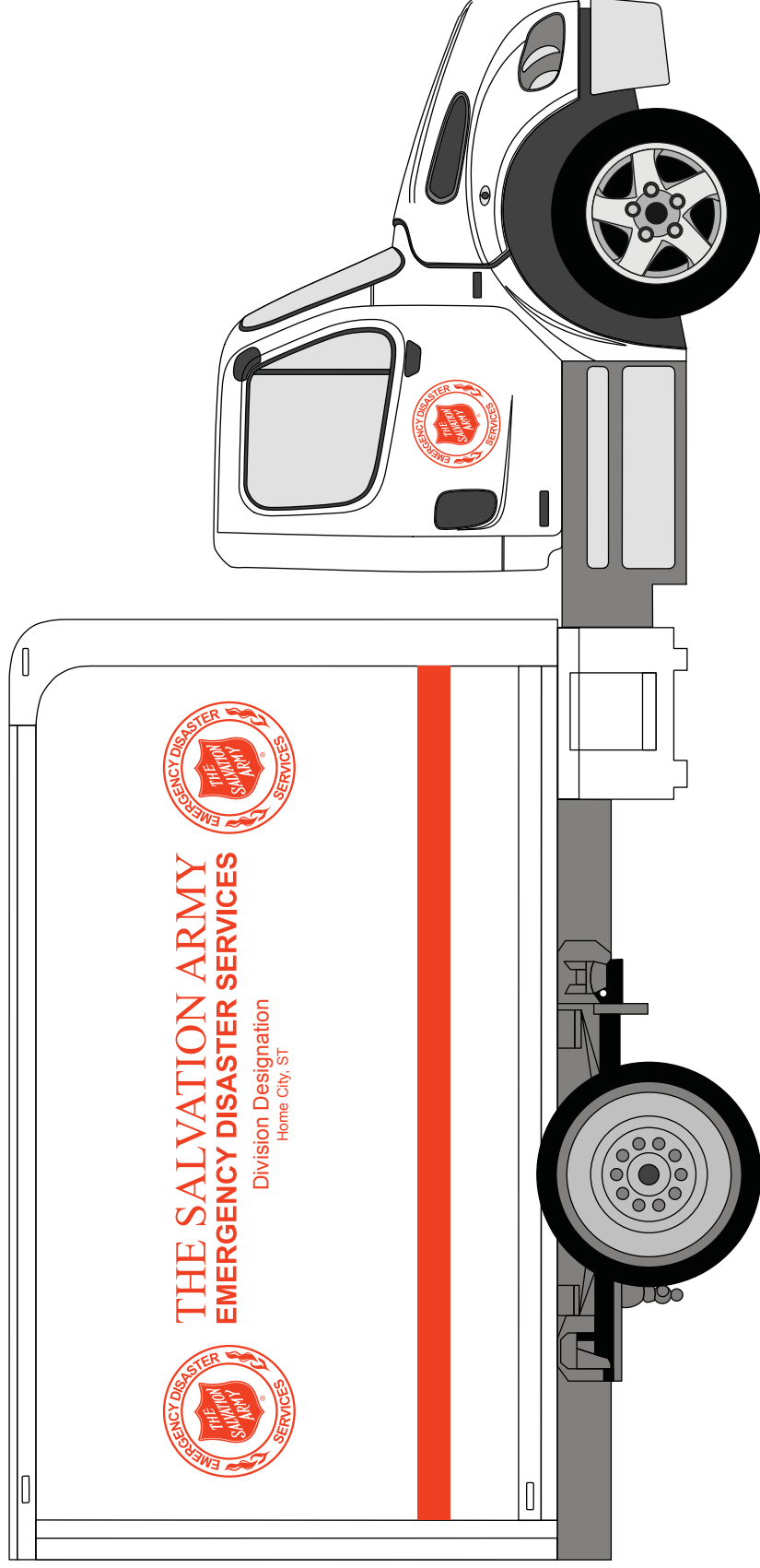
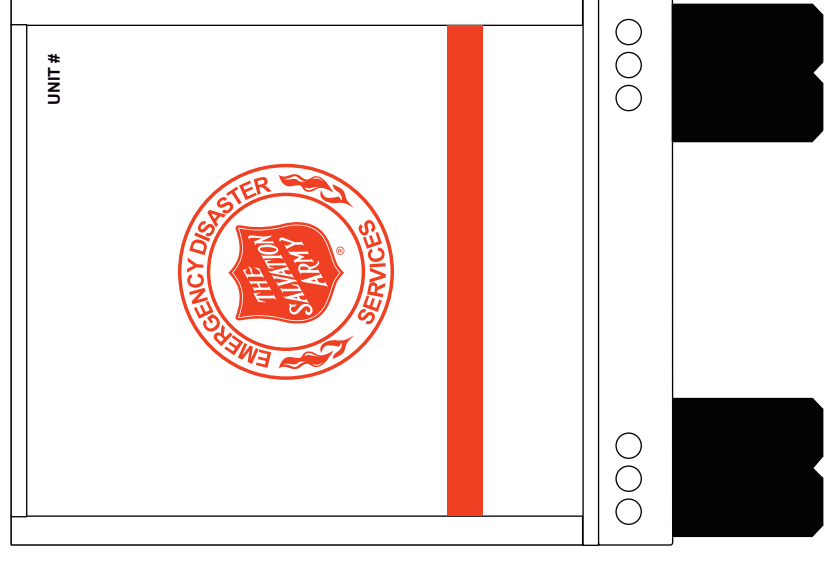
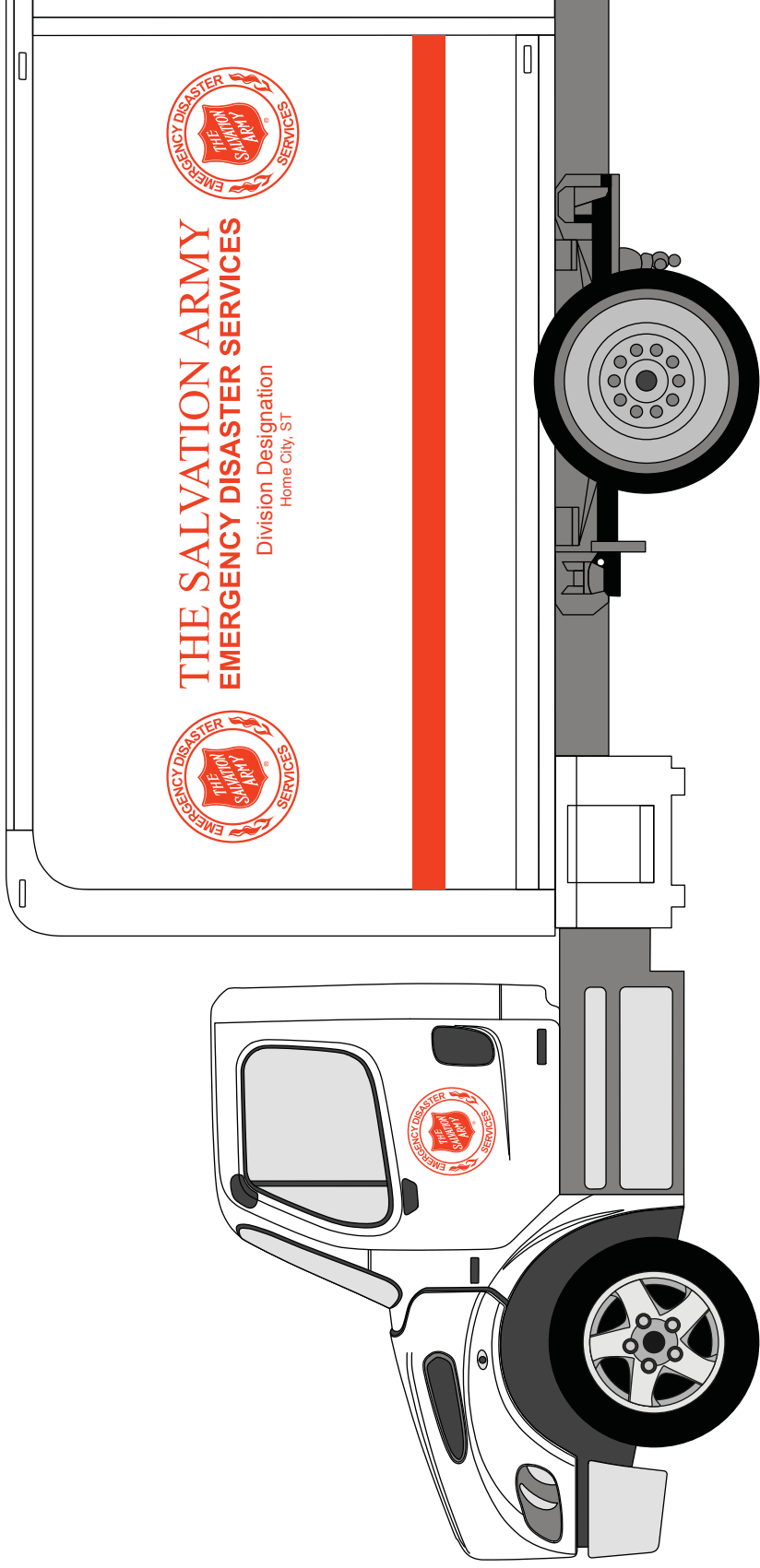

**PLEASE CHECK YOUR ART CAREFULLY**

\*NOTE: Your signature acknowledges responsibility for verifying and confirming that the dimensions, colors, and materials of the artwork are correct for the vehicle's intended use. Lowen Color Graphics is not responsible for graphic placement if the actual dimensions required are different than those listed and approved by the customer on this art rendering. This includes sizing, copy/logo placement, and overall finish. Please check carefully and advise Lowen Color Graphics of any needed graphic changes to this rendering.

This art has been prepared exclusively for our customer and may not be reproduced without written approval from Lowen Corporation. Lowen artwork remains the property of Lowen Corporation until customer purchases it or its intended products. Lowen Corporation reserves the right to bill for unreturned artwork.

Initial the appropriate line, sign and return. Revisions on artwork are subject to a fee.

- Art approved as is (Please review and initial)
- All spelling is correct
- All colors are correct
- All dimensions are correct\*
- Art approved with noted changes
- Changes indicated - prepare revised art

X

Signature \_\_\_\_\_ Date \_\_\_\_\_  
 Approved signature required prior to production.

Salvation Army

Shown: Box Truck | 02 - 22 - 11 | JDK



## **TRACTOR TRAILER**

---

### **TRACTOR**

Hood: EDS Shield (24"+) use maximum white space

Top Banner: "DOING THE MOST GOOD" logo, double or triple line stacked if possible

Side(s): Solid, red, reflective horizontal stripe (15")  
Distance from ground to base of stripe should be 60" with trailer connected

Front Passenger Side: Unit/Divisional identification letter/number (4"), bottom

### **EXCEPTIONS**

Sleeper: EDS Shield (24"+) centered on rear, use maximum white space  
Solid, red, reflective horizontal stripe (15")

Dayrunner: EDS Shield (22"+) centered on each door, use maximum white space  
No reflective stripe

---

### **TRAILER**

Side(s): Solid, red, reflective horizontal stripe (15")  
Distance from ground to base of stripe should be 60" with trailer connected  
White lettering to indicate type of equipment, i.e. "Base Camp Kitchen"  
Lettering to be justified to rear of trailer (Font: Arial)

Side First line: THE SALVATION ARMY, use maximum space (Font: Times New Roman)

Side Second line: EMERGENCY DISASTER SERVICES (Font: Arial Bold)  
Sized to fit the length of the first line

Side Third line: Division Designation (Font: Arial)  
Size not to exceed length of the second line if possible

Side: EDS Shield (36"+ or as space provides) on each side of lettering

### **REAR**

Top Right: Unit/Divisional identification letter/number (4"), passenger side

Door(s): EDS Shield centered above red stripe (28"), or centered on each door (24")

Bottom: Solid, red, reflective horizontal stripe (15")



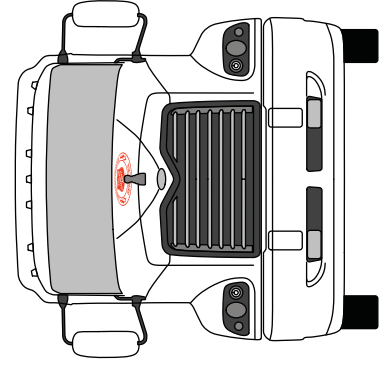
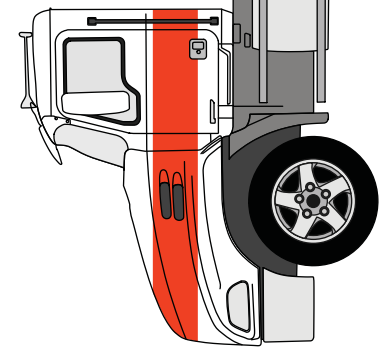
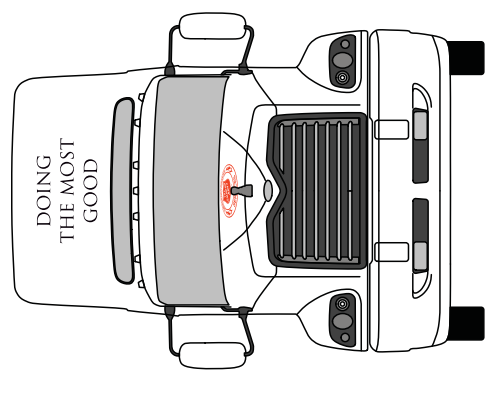
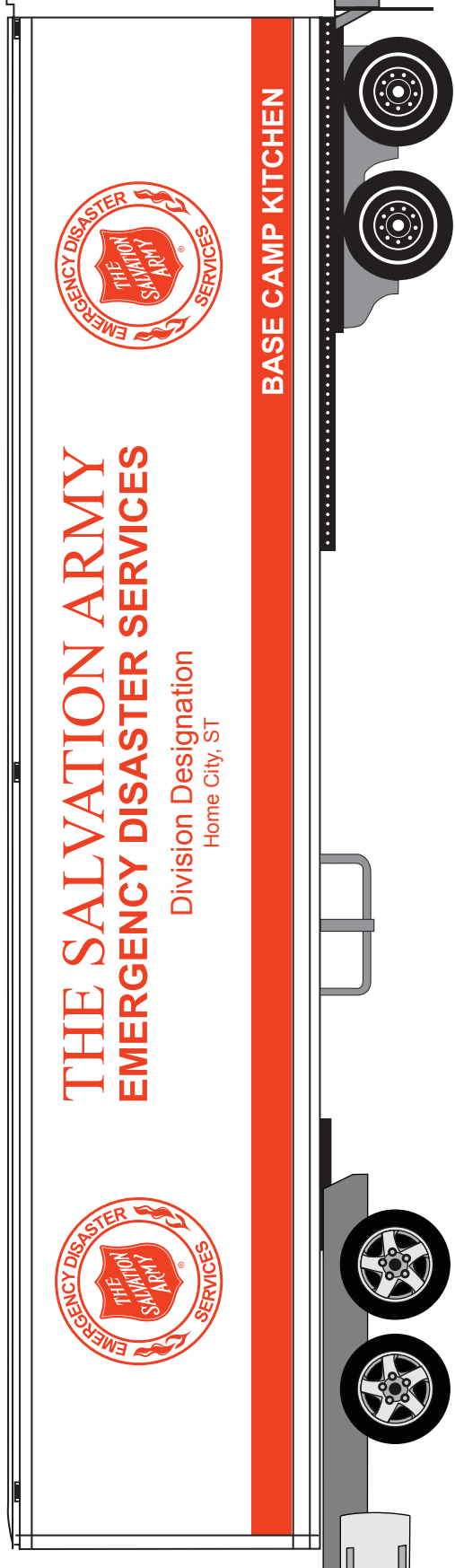
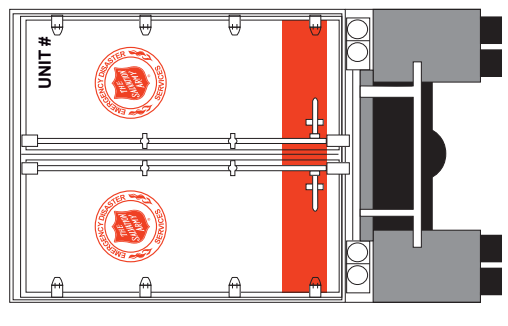

**PLEASE CHECK YOUR ART CAREFULLY**

\*\*NOTE: Your signature acknowledges responsibility for verifying and confirming that the dimensions and colors of the artwork are correct for the vehicle's intended use. Lowen Color Graphics is not responsible for graphic replacement if the actual dimensions required are different than those listed and approved by the customer on this art rendering. This includes sizing, copy/logo placement, and overall finish. Please check carefully and advise Lowen Color Graphics of any needed graphic changes to this rendering.

This art has been prepared exclusively for our customer and may not be reproduced without written approval from Lowen Corporation. Lowen artwork remains the property of Lowen Corporation until customer purchases it or its intended products. Lowen Corporation reserves the right to bill for unreturned artwork.

Initial the appropriate line, sign and return. Revisions on artwork are subject to a fee.

- Art approved as is (Please review and initial)
- All spelling is correct
- All colors are correct
- All dimensions are correct\*
- Art approved with noted changes
- Changes indicated - prepare revised art

X  
Signature \_\_\_\_\_ Date \_\_\_\_\_  
Approved signature required prior to production.





## **COMMAND VEHICLE, SUPPORT VEHICLE**

---

Note: below recommendations are at discretion of division depending on body style of vehicle

### **OPTION A:**

---

#### **SIDE**

Door(s): EDS Logo (12"+) below solid, red stripe  
Body: Solid, red, reflective horizontal stripe (4" - 6")  
From back edge of rear, corner panel to front edge of front panel  
White lettering (3" - 4") to indicate "Division Name", justified to side rear  
(Font: Arial)

#### **FRONT**

Hood: EDS Logo (24"+)  
Bumper: Driver's side, Unit/Divisional identification letter/number (2 ½")  
BLACK on chrome bumper, or RED on white bumper, WHITE on black bumper

#### **REAR**

Body: Solid, red, reflective horizontal stripe (4" - 6")  
Bumper: Passenger's side, Unit/Divisional identification letter/number (2 ½")  
BLACK on chrome bumper, or RED on white bumper, WHITE on black bumper

### **OPTION B:**

---

#### **SIDE**

Door(s): EDS Logo (12"+) embedded in solid, red stripe, instead of below

#### **FRONT**

Hood: EDS Logo (24"+)  
Bumper: Driver's side, Unit/Divisional identification letter/number (2 ½")  
BLACK on chrome bumper, or RED on white bumper, WHITE on black bumper

#### **REAR**

Body: Solid, red, reflective horizontal stripe (4" - 6")  
EDS Logo (12"+) embedded in solid, red stripe  
Bumper: Passenger's side, Unit/Divisional identification letter/number (2 ½")  
BLACK on chrome bumper, or RED on white bumper, WHITE on black bumper





**OPTION A:**

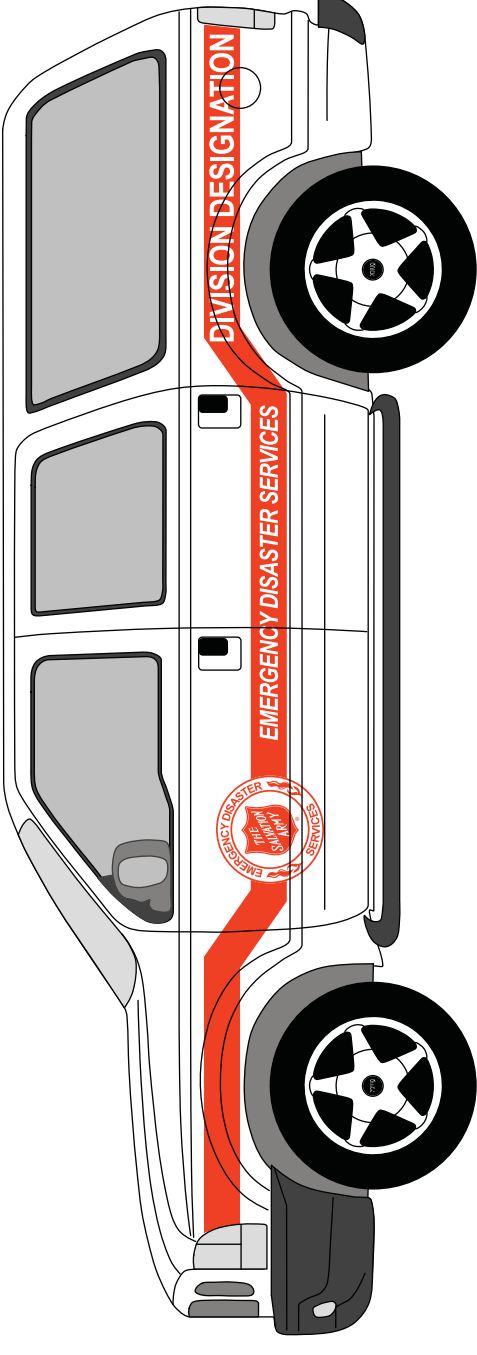
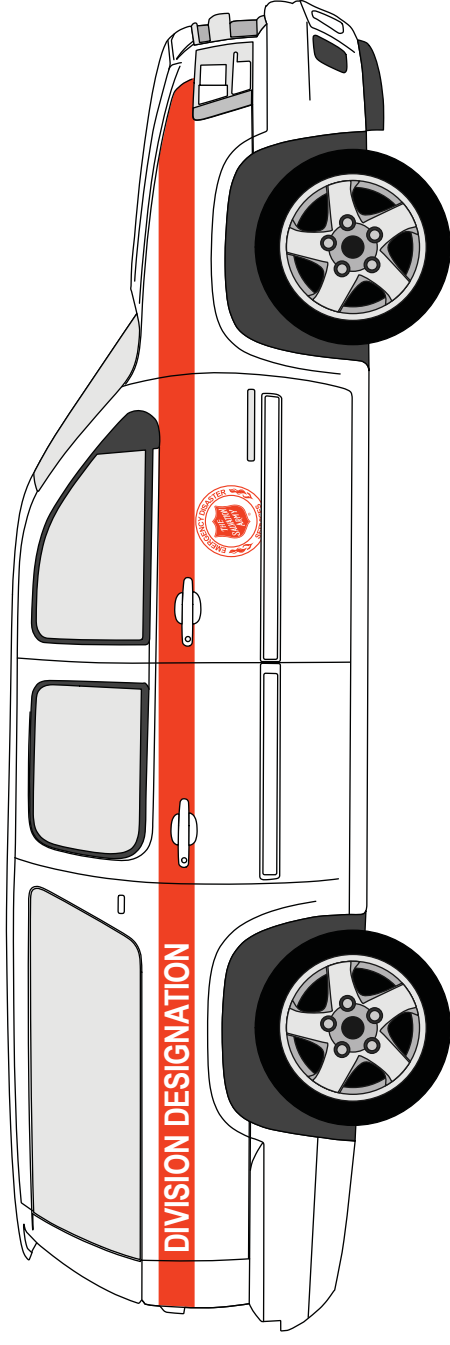
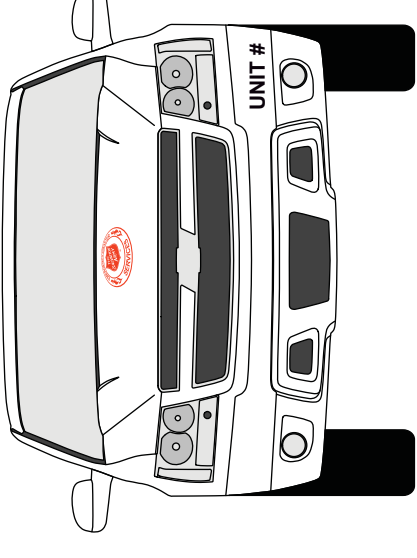
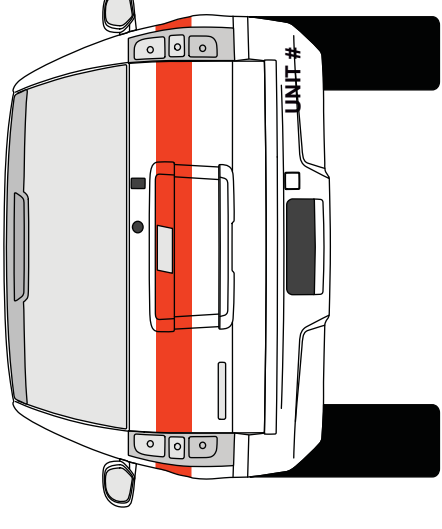
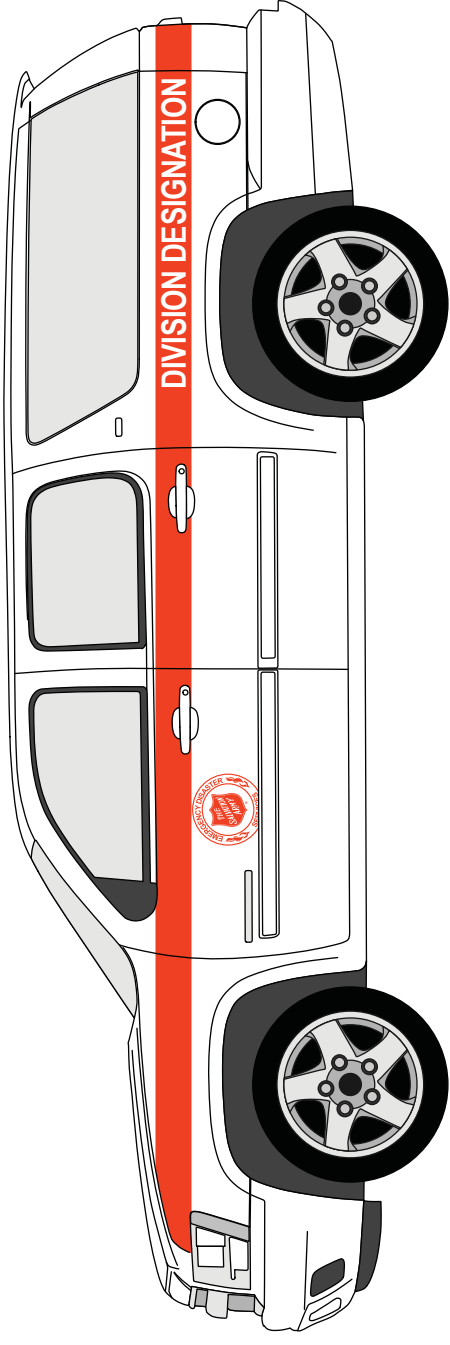

**OPTION B:**

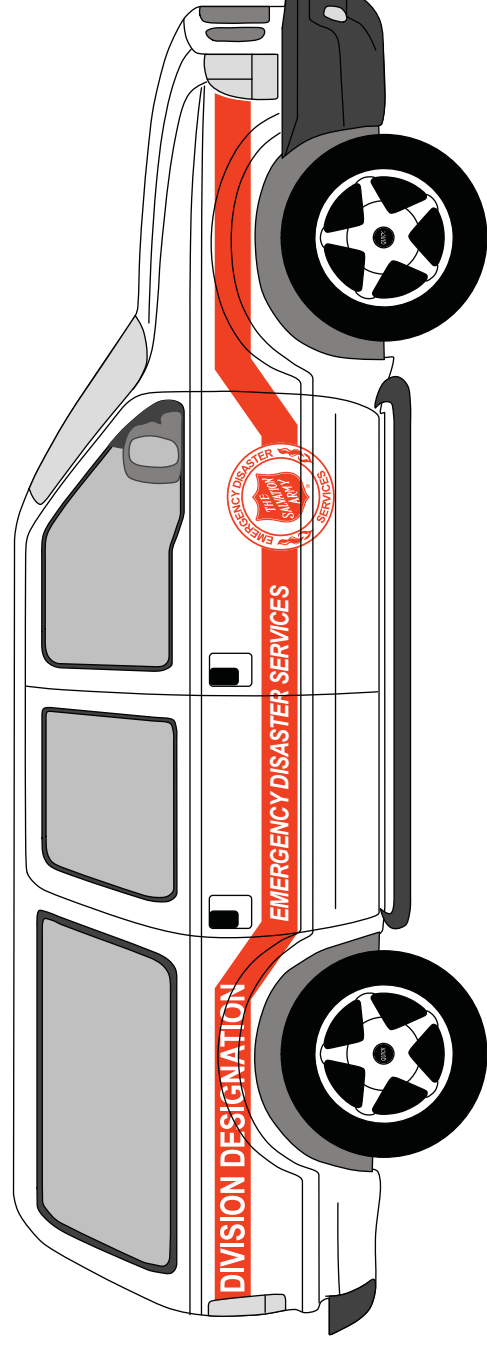
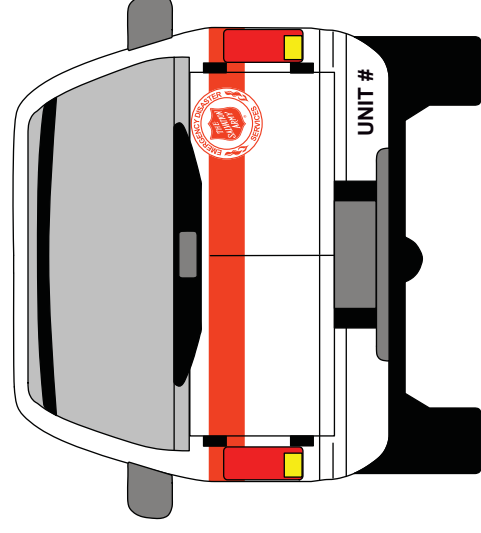
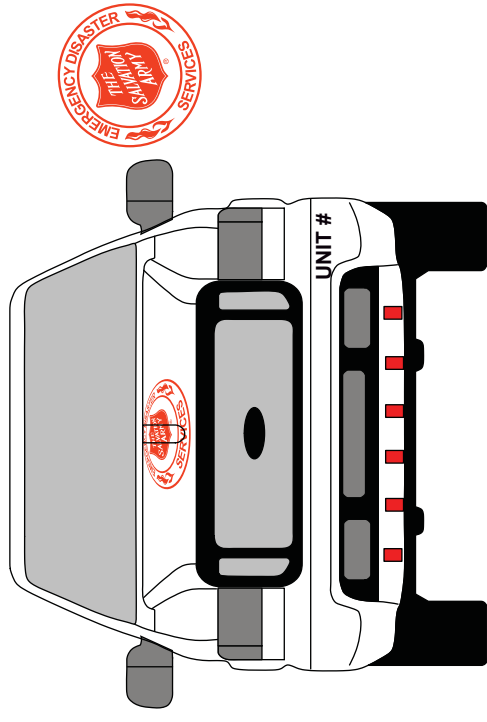

**PLEASE CHECK YOUR ART CAREFULLY**

\*NOTE: Your signature acknowledges responsibility for verifying and confirming that the art meets the intended use. Lowmen Color Graphics is not responsible for graphic replacement if the actual dimensions required are different than those listed and approved by the customer on this art rendering. This includes sizing, copy/logo placement, and overall fit/finish. Please check carefully and advise Lowmen Color Graphics of any needed graphic changes to this rendering.

This art has been prepared exclusively for our customer and may not be reproduced without written approval from Lowmen Corporation. Lowmen artwork remains the property of Lowmen Corporation until customer purchases it or its intended products. Lowmen Corporation reserves the right to bill for unreturned artwork.

Initial the appropriate line, sign and return. Revisions on artwork are subject to a fee.

\_\_\_ Art approved as is (Please review and initial)

\_\_\_ All spelling is correct

\_\_\_ All colors are correct

\_\_\_ All dimensions are correct\*

\_\_\_ Art approved with noted changes

\_\_\_ Changes indicated - prepare revised art

X

Signature

Approved signature required prior to production.

Date

Salvation Army

Shown: Command Support Vehicles | 02 - 22 - 11 | Rev. 1 | JDK



COLOR GRAPHICS

A DIVISION OF LOWMEN CORPORATION

Graphics That Mean Business®



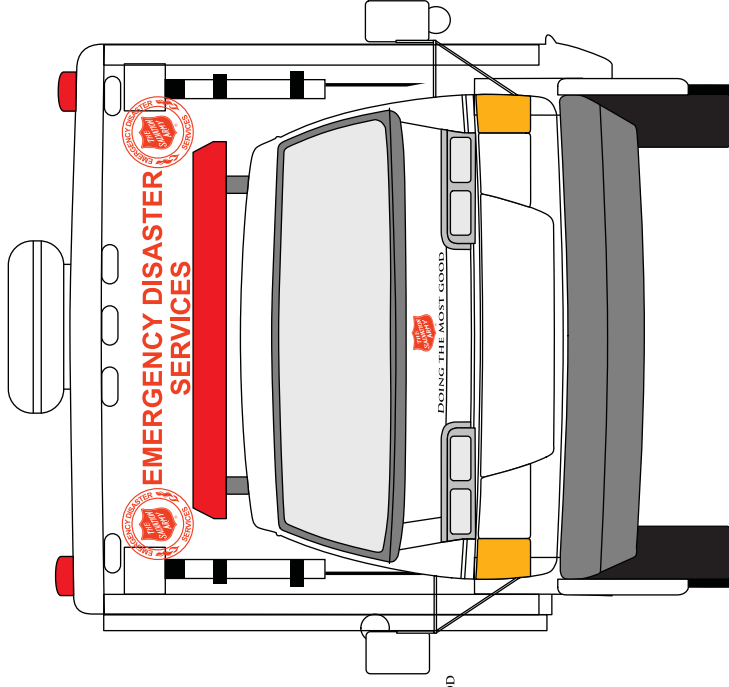
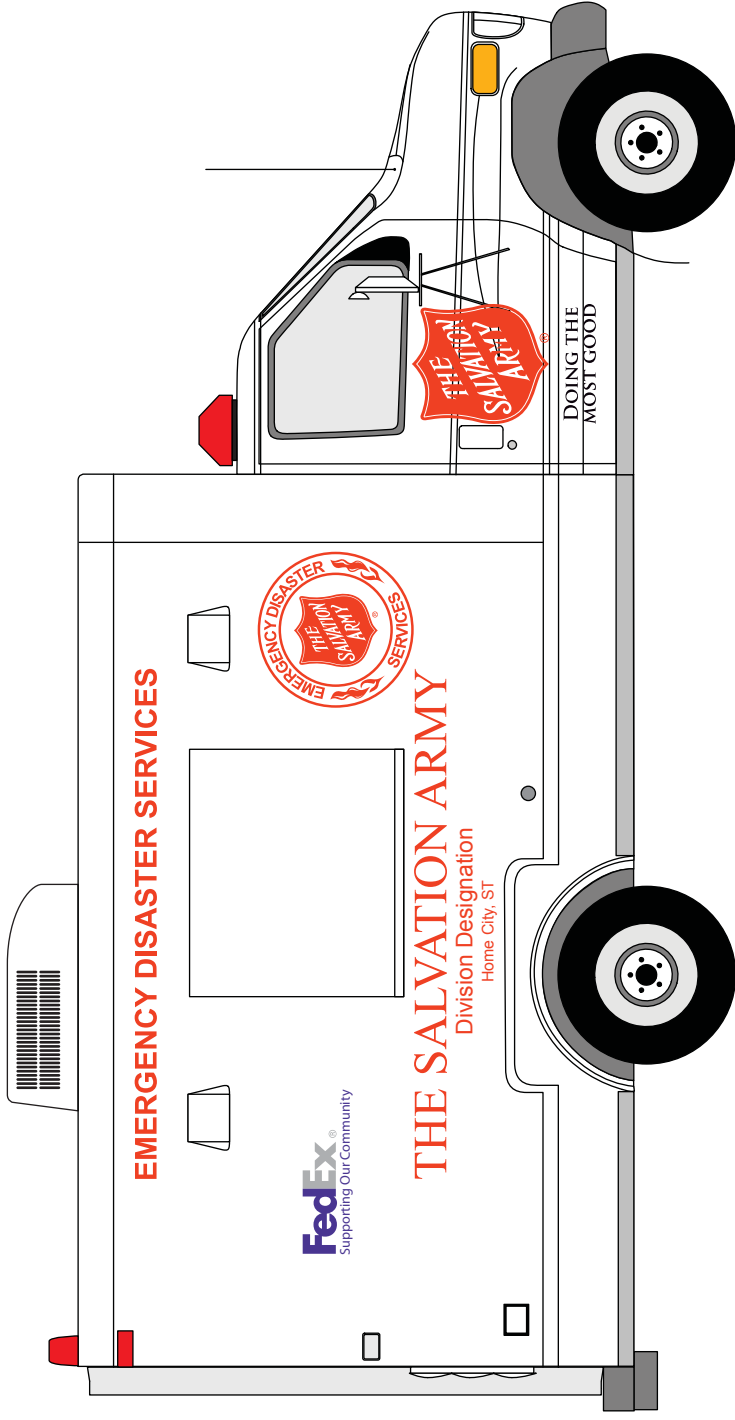
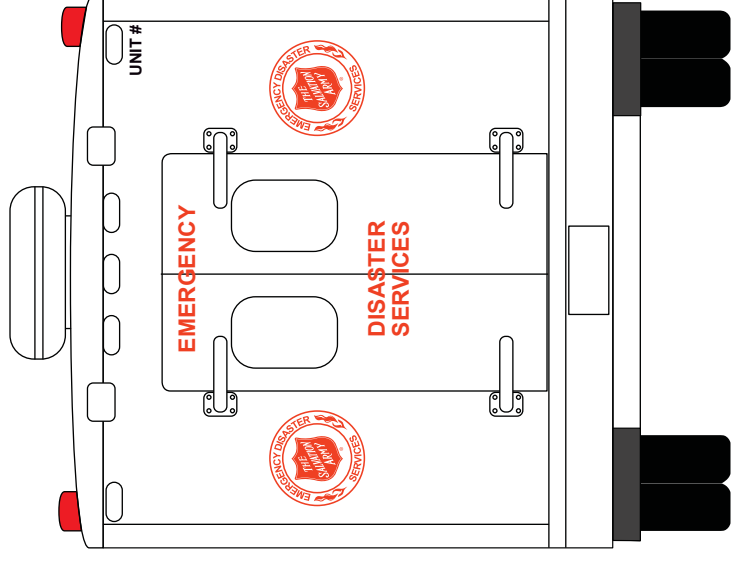
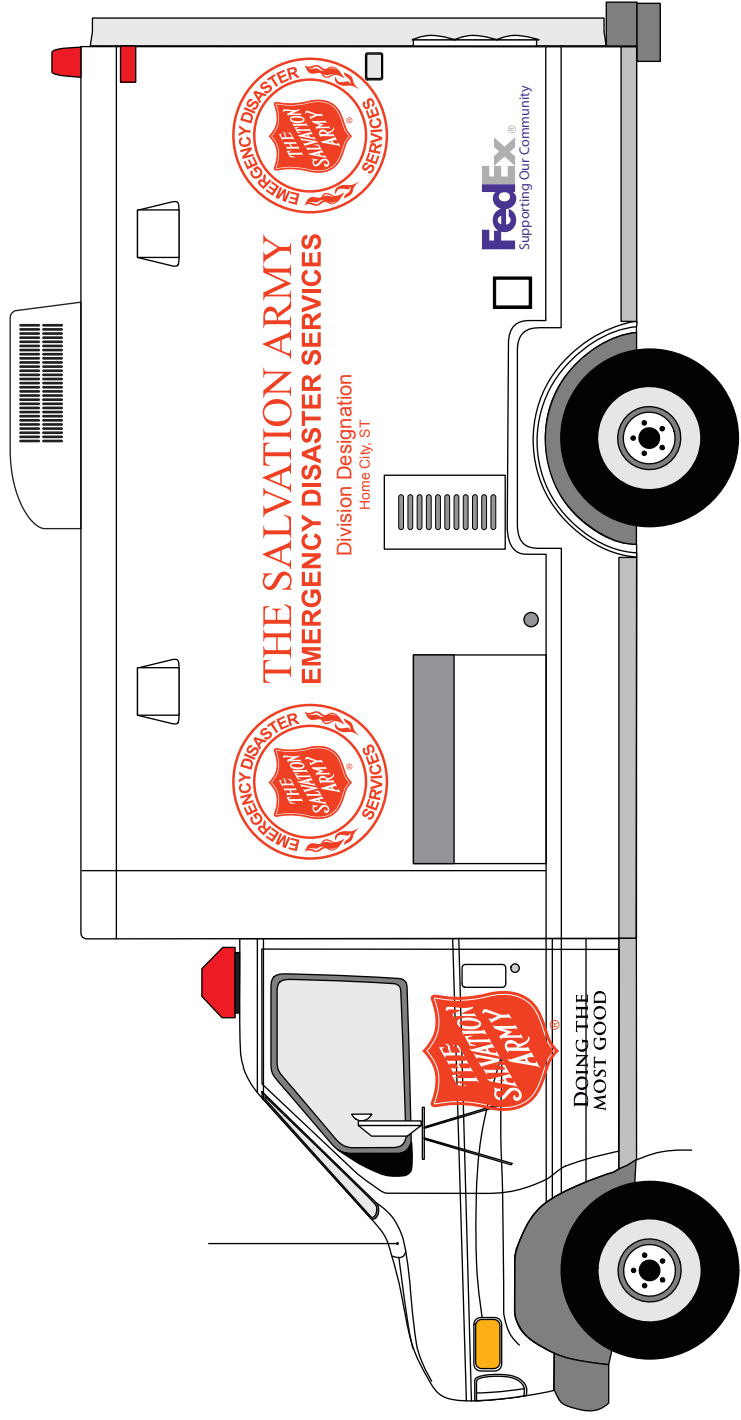

**PLEASE CHECK YOUR ART CAREFULLY**

\*NOTE: Your signature acknowledges responsibility for verifying and confirming that the dimensions and colors of the artwork are correct for the vehicle's intended use. Lowen Color Graphics is not responsible for graphic replacement if the actual dimensions required are different than those listed and approved by the customer on this art rendering. This includes sizing, copy/logo placement, and overall finish. Please check carefully and advise Lowen Color Graphics of any needed graphic changes to this rendering.

This art has been prepared exclusively for our customer and may not be reproduced without written approval from Lowen Corporation. Lowen artwork remains the property of Lowen Corporation until customer purchases it or its intended products. Lowen Corporation reserves the right to bill for unreturned artwork.

Initial the appropriate line, sign and return. Revisions on artwork are subject to a fee.

\_\_\_ Art approved as is (Please review and initial)

\_\_\_ All spelling is correct

\_\_\_ All colors are correct

\_\_\_ All dimensions are correct\*

\_\_\_ Art approved with noted changes

\_\_\_ Changes indicated - prepare revised art

X

Signature

Approved signature required prior to production.

Signature

Approved signature required prior to production.

Date

Date

Salvation Army

Shown: Keystone Coachworks 12' DRU | 05 - 22 - 12

JDK



COLOR GRAPHICS

A DIVISION OF LOWEN CORPORATION

Graphics That Mean Business®